

An automated priority switching matrix which allows as many as ten communications circuits to be dynamically connected to five High-Power Amplifiers (HPAs). The RF switch dynamically allocates the HPAs so that in the event of an HPA failure, communication is not lost.



PRIORITY SWITCHING MATRIX

The SA-2768/U is an automated priority switching matrix that allows five High-Powered Amplifiers to be used with up to ten communications channels. All inputs operate on a declining priority scheme. In the event more channels attempt to transmit than there are HPAs, the highest priority channels get access. All circuit types can be accommodated by giving the highest priority to a circuit that could not tolerate a missed transmit event. Without the RF switch, a failed HPA causes the loss of the entire channel. With the RF switch, the channels are gracefully degraded down to the last HPA. In addition, the SA-2768/U reduces the number of HPAs required, lowering overall SA-2768/U Broadband Radio Frequency Switch system size, weight and cost.

RADIO COMPATIBILITY — INITIALLY INTEGRATED WITH MD-1324 AND DMR

The SA-2768/U is a broadband switch for UHF and VHF channels. In addition to eight general purpose RF input channels, the switch supports operation with two MD-1324A modems sharing one WSC-3 for transmission. This dedicated interface captures the tuning commands from the MD-1324A and reprograms the WSC-3 after each switch. The WSC-3 uses the ViaSat-designed A-20 upgrade drawer for automatic frequency tuning by the MD-1324A DAMA modem.

OPTIONAL UP-CONVERTER — FOR INCREASED CAPABILITY WITH 1324 SERIES MODEMS

The optional satcom up-converter is used with the MD-1324A modem. It is installed inside the switch chassis and converts the 70 MHz IF to UHF and then sends it on to the HPAs for priority routing. This allows two MD-1324A modems to share the HPAs and eliminates the requirement for radios. A second up-converter can be installed if unique priorities are desired for each of the MD-1324A modems.

EASE OF OPERATION — SIMPLE TO USE

The front panel provides switch status LED indicators and manual control switches. LEDs indicate the keying status of the input and output ports. Amber indicates the port is keyed and selected, while red indicates the port is not keyed. In the event of a PA failure, toggle switches are provided to turn off that output port manually, which would then be indicated with a red LED. Low level PA status inputs are also provided on the back panel to implement this function automatically. When using the internal up-converters, the priority of each MD-1324A can be set independently.

NOMINAL PERFORMANCE

Bandwidth 2-500 Mhz

Loss < 3.0 dB

Nominal Impedance 50 ohms

Input VSWR 1.5:1

Output VSWR 1.5:1

Isolation > 40 dB

Input Power 19 W, 85 to 264 VAC, 47-440 Hz

Temperature 0° C to 50° C

PHYSICAL CHARACTERISTICS

Dimensions 2U enclosure, 3.469 x 19 x 22 in

Weight 13 lb

SA-2768/U VHF/UHF Broadband Radio Frequency Switch

SPECIFICATIONS

INTERFACES

General Purpose 8X5 Matrix

RF Inputs Eight TNC connectors grouped in two sets IF inputs of four, 2MHz- 500 MHz, 50 ohm nominal impedance

RF Keylines Two 9-pin Dsub connectors supporting eight discrete ground level keyline inputs

RF Outputs Five TNC connectors output priority IF output selected RF inputs with less than 3 dB loss

HPA Keylines One 15-pin Dsub connector supporting five WSC-3 Control discrete ground level HPA keyline outputs

HPA Status One 15-pin Dsub connector supporting five discrete ground level HPA status inputs Frequency Reference Input

Power Source 115 VAC, 60 Hz

MD-1324A 2X1 Matrix

IF Inputs Two TNC connectors, 69- 71 MHz, 50 ohm nominal impedance

Modem Control Two 9-pin Dsub connectors supporting keyline and frequency tuning interface commands from the MD-1324A modem

IF Output One TNC connector output the selected IF input with less than 3 dB loss

WSC-3 Control One 9-pin Dsub connector supporting keyline and frequency tuning interface commands to the WSC-3 Radio

Frequency Reference Input Two TNC connectors only used when internal upconverters are installed; 1, 5 or \pm 10 dBm

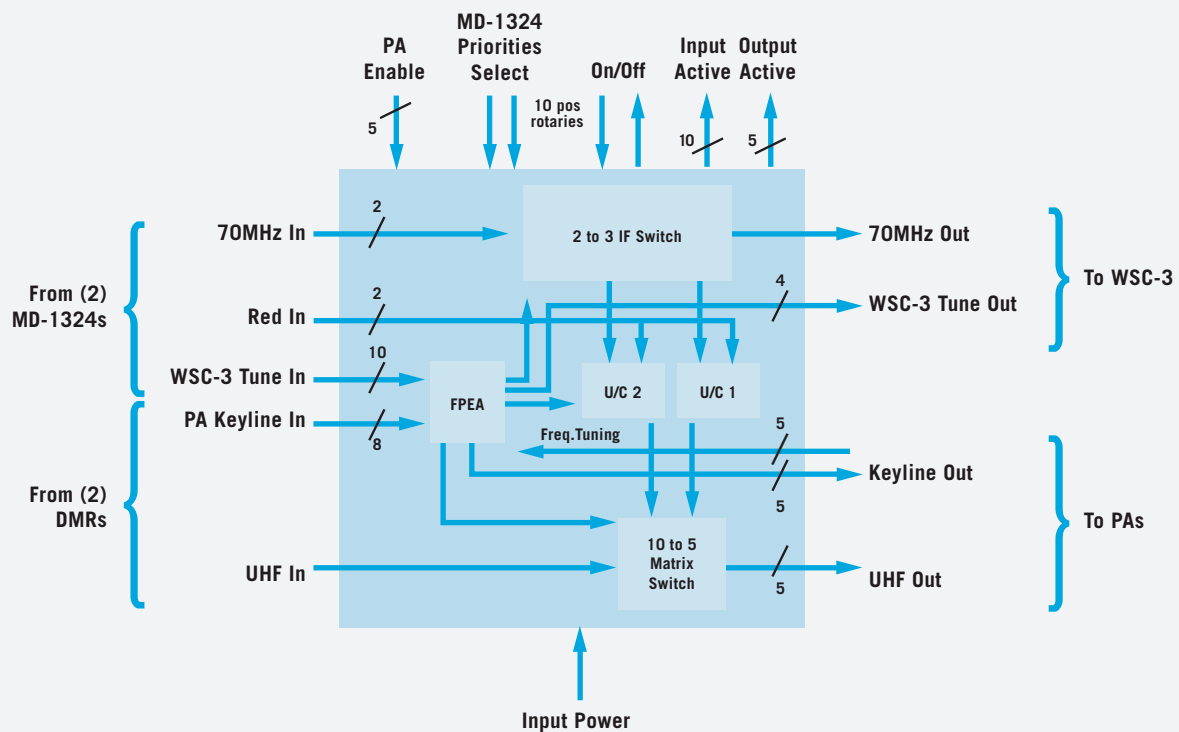

CONTACT

6155 EL CAMINO REAL, CARLSBAD, CA 92009

SALES

TEL 760.476.2472 FAX 760.929.3968 EMAIL GOV.SATCOM@VIASAT.COM WEB WWW.VIASAT.COM

TECHNICAL SUPPORT

TEL 760.476.2457

