

Software Manual

Calibration Software

Windows 95/98/ME/NT/2000/XP

For Model 8861/62/64

Antenna Position Controllers

1008111-001



Technical Manual

Calibration Software

for Windows 95/98/ME/NT/2000/XP

For Model 8861/62/64

Antenna Position Controllers

Data, drawings, and other material contained herein are proprietary to ViaSat, Inc. and may not be reproduced or duplicated in any form without the prior permission of ViaSat, Inc.

When ordering parts from ViaSat, Inc. be sure to include the equipment model number, equipment serial number, and a description of the part.

In all correspondence with ViaSat, Inc. regarding this publication, please refer to:

1008111-001

First Edition – June, 2003

Copyright 2003 by ViaSat, Inc.

All rights reserved. No part of this manual may be reproduced in any form or by any means, without permission in writing from ViaSat, Inc.



FORWARD

The following paragraphs provide the user with a brief antenna control system description, and a list of other technical manuals that contain information related to the system.

The ViaSat antenna control system has been designed with a modular architecture capable of meeting a wide variety of antenna positioning and tracking requirements. The system consists of several components, not all of which are needed for any particular antenna installation:

Model 8860 Antenna Tracking Controller

Model 8861A Antenna Position Controller, Single Speed (1 hp max.)

Model 8862 Antenna Position Controller, Variable Speed (2, 5, 10 hp)

Model 8861 Antenna Position Controller, Single Speed (1 hp max.), Replaced by 8861A

Model 8864 Antenna Position Controller, Variable Speed (10 hp max.), Replaced by 8862

Model 7670 Earth Station Controller

The Models 8861, 8861A, 8862, and 8864 provide basic positioning capability in response to commands sent from a host serial device such as the 8860 or a computer. These units process the position feedback and limit switch signals and control the drive for the actuator motors. The 8861/8861A provides a low-cost single-speed drive control for antennas that do not require fast antenna motion. The 8862/8864 provides dual-speed control, via variable frequency drives, for applications that require fast positioning (high speed) and satellite tracking (low speed.) The use of variable speed drives, on the 8862/8864, provides for flexible adjustment of low and high speed performance, as well as eliminating the need for expensive dual-wound motors.

The 8860 Antenna Tracking Controller provides the operator with a control panel containing a LCD display and keypad. It also processes beacon or carrier level inputs and commands the position controller when tracking motion is required. The 8860 communicates with the position controller via an RS-422 serial communication link that is optically isolated and equipped with transient protection. The 8860 also provides an RS-422 connections for the use of an 7670 (or similar) Earth Station Controller, and an RS-232 connection for use with a modem or personal computer. Each of the serial ports utilize the proprietary SABus protocol for communications.

During antenna electrical installation, the position controller is calibrated and tested using special calibration software that runs on a personal computer. If an 8860 is being used, the personal computer can be connected to the 8860 in order to perform the calibration and test. In addition to calibration of the position controller, the calibration software can be used to upload and/or download information such as satellite position or tracking data.

Below is a list of related manuals:

<u>Manual Number</u>	<u>Description</u>
557660	8860 Antenna Tracking Controller Operations Manual
42S054	8861 Position Controller Technical Manual
42S121	8862/8864 Position Controller Technical Manual
551419	8861A/8862 Position Controller Technical Manual
42S097	DOS Calibration Software Manual
551410	Windows Calibration Software Manual
42S053	8860 Installation and Maintenance Manual
42S057	8861 4.5 Meter Electrical Installation Manual
42S058	8861 6 Meter Electrical Installation Manual
42S059	8861 7 Meter Electrical Installation Manual
42S060	8861 9/10/11 Meter Electrical Installation Manual
42S119	8862/64 16/18 Meter Electrical Installation Manual
42S157	8861 6 Meter (180 ⁰) Electrical Installation Manual.

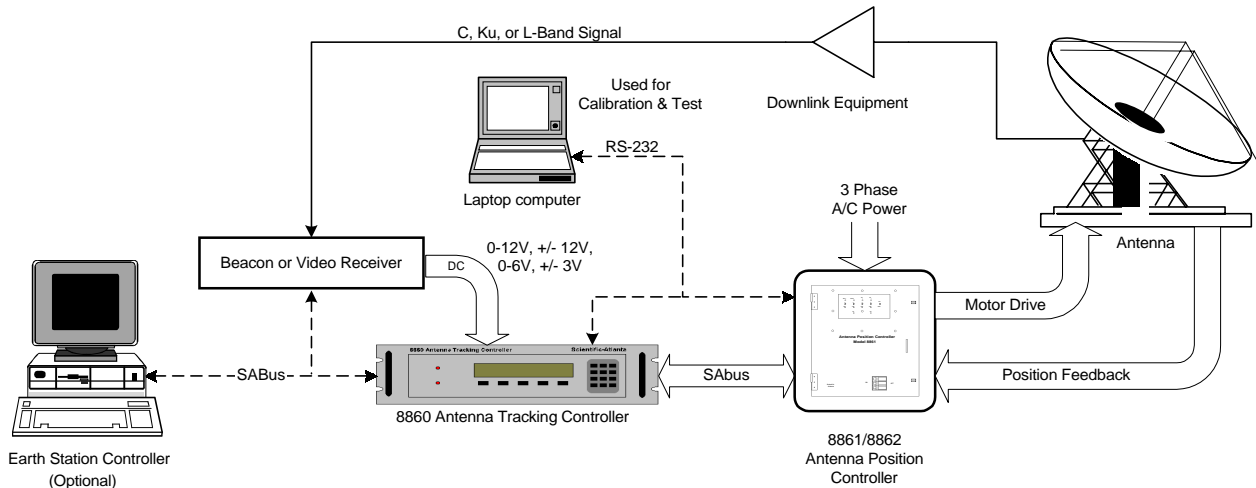

Simplified Block Diagram of Antenna Control Components

TABLE OF CONTENTS

SECTION 1 GENERAL INFORMATION

- 1-1 INTRODUCTION TO MANUAL
- 1-1 INSTALLATION AND CALIBRATION SUMMERY
- 1-2 PROGRAM DESCRIPTION
- 1-2 INSTALLING THE SOFTWARE
- 1-3 CONNECTING TO THE APC

SECTION 2 DETAILED OPERATION

- 2-1 REVISION HISTORY
- 2-2 INTRODUCTION
 - 2-2 - Installation
 - 2-2 - Running The Program
 - 2-3 - Connecting to the 8861/2
- 2-3 ANTENNA CALIBRATION ROUTINES
 - 2-3 - Activating Polling
 - 2-4 - Setup Checklist
 - 2-4 - Verifying Motion
 - 2-5 - Checking Limit Switches
 - 2-6 - Calibrate Look Angle
 - 2-6 - General Setup
 - 2-9 - Axis Setup
 - 2-10 - Feed Setup
 - 2-13 - Limit Setup
 - 2-14 - Dynamic Calibration
- 2-15 ADVANCED CALIBRATION

SECTION 3 UTILITIES

- 3-1 INTRODUCTION
 - 3-1 - Pattern Movement
 - 3-2 - SAbus Monitor
 - 3-2 - Pointing Calculator
 - 3-4 - File Editor
 - 3-4 - 8860 Sats
 - 3-5 - Program Track
 - 3-6 - Intelsat Data

APPENDIX A SABUS COMMAND SET (8861/2/4)

SECTION 1 GENERAL INFORMATION

**INTRODUCTION TO
MANUAL**

This manual contains information needed to properly install and operate the Windows based calibration software for the Model 8861, Model 8862, and Model 8864 Antenna Position Controllers. Section 1 provides a brief description along with basic installation and operating instructions. Section 2 provides more detailed operating instructions.

ViaSat, Inc. makes every effort to ensure that the information contained herein is correct and complete.

**INSTALLATION AND
CALIBRATION
SUMMARY**

This manual should be used in conjunction with the appropriate antenna and controller installation manuals and drawings in order to properly calibrate the pointing movement of the antenna. Before attempting the calibration process, the antenna and APC basic operating functions should be verified. The 8861/62/64 APC provides toggle switches that can be used to verify the following:

1. Motor Rotation
2. Limit Switch Operation

The calibration software can be used as an aid to troubleshooting certain APC problems, but prior to such usage, the appropriate control components should be checked for proper wiring and installation. Once the wiring and installation has been verified, the calibration software will provide the needed tools for testing and calibrating the antenna positioning controls.

PROGRAM DESCRIPTION

The calibration software is written to run under the Microsoft Windows operating system. It communicates with the 8861/62/64 Antenna Position Controller via a serial interface and utilizes the SAbus command set. During the calibration process, the software sends commands that write data to the antenna position controller's non-volatile EEPROM. This data is primarily used by the controller to scale and/or offset position data so that accurate pointing data can be determined. Some of this stored data is also used to determine other configuration parameters. The Windows environment provides the user with an interface that allows easy access to the variety of features needed to configure the APC. The interface can also function as a remote means of repositioning the antenna in the absence of an 8860 Antenna Tracking Controller or 7670 Earth Station Controller. When used in this manner, it is not intended as a permanent means of controlling the antenna; but rather as an occasional or temporary means.

The software is designed for use on an IBM compatible computer running either the Windows 3.x or Windows 95 operating system. The minimum requirements are:

- CPU - 486 or higher
- Memory - 8 MB or more
- Disk Space - 10 MB available
- Floppy Disk - 3.5" 1.44 MB
- I/O - 1 or more serial (COM1- COM4) available

These modest requirements make it possible to run the software on a variety of laptop or desktop computers that can be found in wide use. It should be noted, that the serial port needs to be available for use, and not already connected to a mouse or similar pointing device. While it is possible to use the software without a pointing device, the use of one will greatly simplify the use of the software.

INSTALLING THE SOFTWARE

The software comes on CDROM. Inserting the CDROM in the computer CDROM drive should start the setup automatically. If not, use Windows Explorer to browse the CDROM for the SETUP.EXE file. Double-click on this filename to start the setup routine. If the computer you wish to run the software on does not have a CDROM drive, another computer with a CDROM drive can be used to create floppy disks for installing the software.

To create floppy disks for installation:

1. Browse the CDROM for the **Install_Zip** directory.
2. Insert a blank floppy disk in the a: drive
3. Double-click the **DISK1.EXE** file on the CDROM
4. Extract the files to the floppy disk #1
5. Replace the floppy with another blank floppy
6. Double-click the **DISK2.EXE** file on the CDROM
7. Extract the files to the floppy disk #2
8. **SETUP.EXE** on floppy disk #1 will be used to install the software on the computer without a CDROM.

CONNECTING THE PC TO THE APC

To use the Calibration Software, the PC needs to be connected to the APC via the computers RS-232 serial port. This port can be assigned as COM1 to COM4. A 9-pin straight-thru cable can be used to connect directly to the 8861/62/64 RS-232 connector. Alternatively, the PC can be connected to the 8860 (if installed) by using a 9-pin null-modem cable. These cables can be easily obtained at most computer stores or can be fabricated according to the below diagrams.

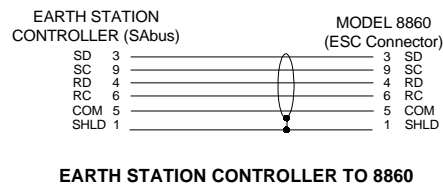
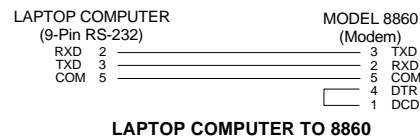
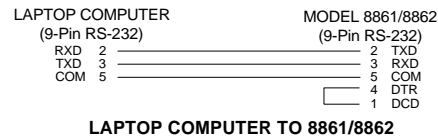
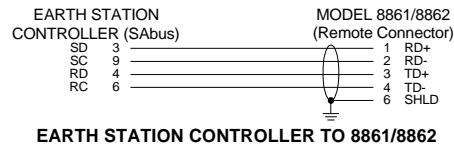
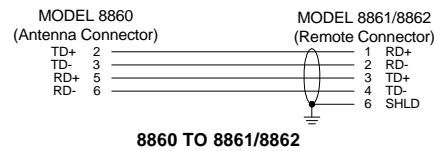

REVISION HISTORY

- June 15, 2003** **V3.2**
Release for Production

- April 15, 1997** **V3.0b**
Release for Production

- October 14, 1997** **V3.0 Beta**
- Initial Beta Test release for customer/ Installer evaluation

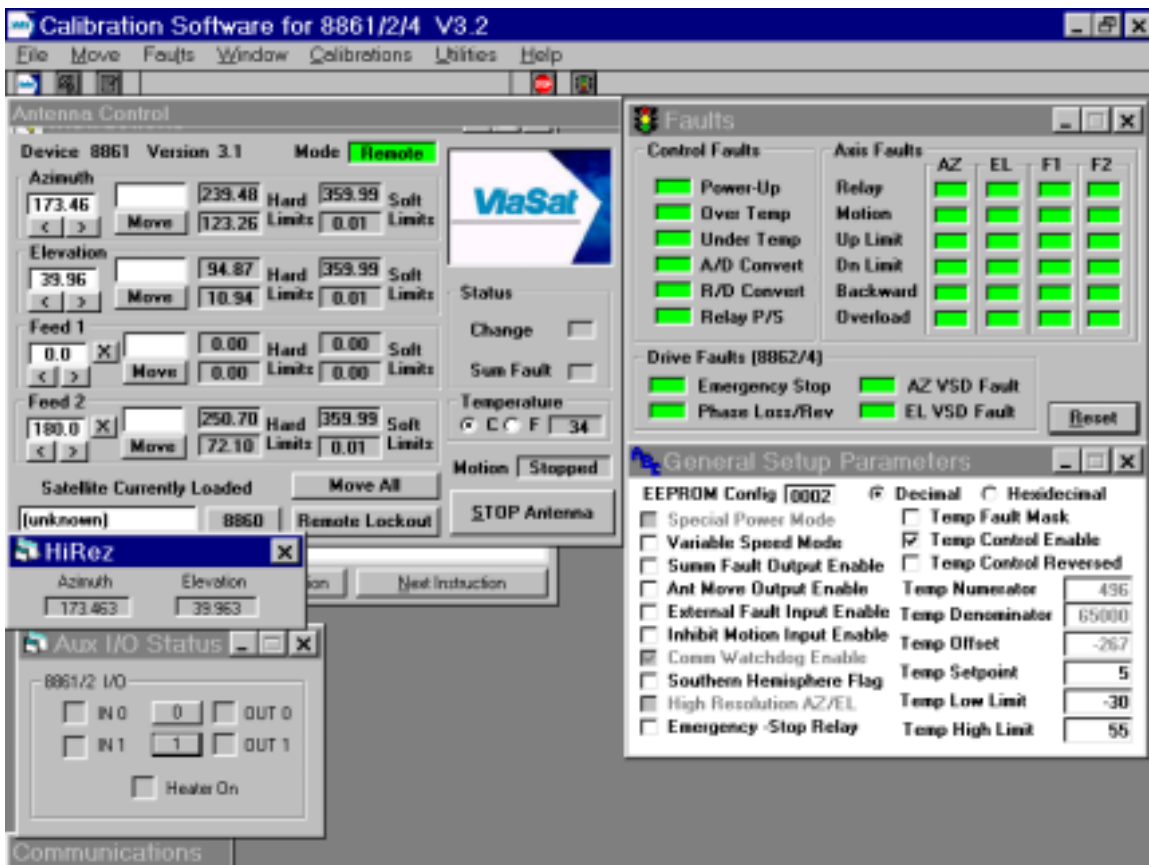

INTRODUCTION

The 8861/2/4 Calibration Software is a PC application designed to operate under Microsoft's Windows 95/98/NT/2000/XP. The software functions as a Virtual Device that operates similarly to a hardware Antenna Control Unit (ACU). The Antenna Control screen has controls and indicators that operate much the same as the front panel of an ACU. Using a standard RS-232 port on the PC, the software communicates with the ViaSat 8861 or 8862 Antenna Controller which mounts on or near the antenna base. Alternatively, the PC can be connected to an 8860 Antenna Tracking Controller which in turn is connected to the 8861 or 8862 via an RS-422 interface.

In addition to basic antenna control functions, the software contains routines used to setup and/or calibrate the 8861 or 8862. It also contains some utility routines that are useful for calculating pointing angles and for uploading information to the 8860. An SABus monitor utility is useful for testing and troubleshooting the SABus connection for not only the 886x devices, but other SABus devices as well.

Installation

The software is contained on CDROM and installs to the computer hard disk. The minimum recommended system requirements are:

CPU	80486 or higher compatible
Memory	8 MB or more (16 MB recommended)
Operating System	Windows 95/98/ME/NT/2000/XP
Hard Disk Space	10 MB available
CDROM Drive	Windows Compatible
I/O	1 COM port Available (not used for mouse)
Pointing Device	Compatible with Windows

To install the software do the following:

1. Insert Setup CDROM in Computer's CDROM Drive
2. The SETUP.EXE on the CDROM should start automatically if not:
3. Use Windows Explorer to Open the CDROM and double-click on SETUP.EXE
4. Follow the prompt messages and insert addition disk/s when prompted

Running The Program

After the Setup program completes, the program will be ready to run. From Windows Start button you just open the Program Group. Locate the icon for the 886XCALIBRATION under the Programs tree, and click on the icon.

Connecting to the 8861/2

If your antenna has a 8860 Antenna Tracking Controller, the easiest way to connect the computer is to use a null-modem cable between the computer serial port and the Modem port on the back of the 8860. If your antenna does not have an 8860 or you want to bypass the 8860, you can connect a standard straight-thru cable between the computer serial port and the RS-232 port on the 8861/2.

ANTENNA CALIBRATION ROUTINES

Activating Polling

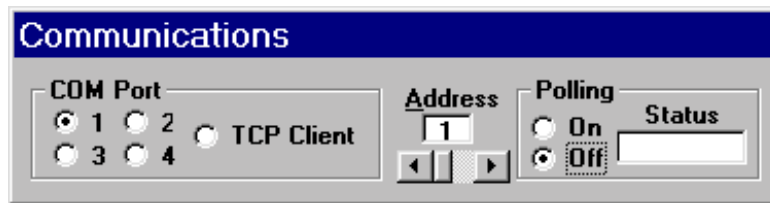

For the *Antenna Control* to function and to perform Controller Calibrations. The software must be polling the 8861/8862 controller. In order to poll the controller follow these steps:

1. Connect the computer serial port (COM1 - COM4) to either the 8860 Modem port (using a null-modem cable), or the 8861/2 RS-232 port (using a straight-thru cable.)
2. The 8861/2 address should be set to 1. If and 8860 is used, set it's address to 3.
3. On the Communications screen select the *Comm Port* (1-4) used by the computer.
4. Select either address 1 (if computer is connected direct to the 8861/2) or address 3 (if the computer is connected to an 8860.)
5. Select the *Polling On* option button.
6. If the connection to the 8861/2 is good, the Antenna Control screen should display the current position indications of the antenna along with limits and other data. The Communications screen should minimize to an Icon or Task Bar

Note: If the Communications screen does not minimize automatically, then there is a problem with the communications settings, cables, or computer COM port. Recheck the addresses first, then the cables, and finally the computer to isolate the problem.

Setup Checklist

In order to access certain calibration routines, the operator must review a checklist and answer questions regarding the configuration and operation of the antenna controller. To activate this checklist follow these steps:

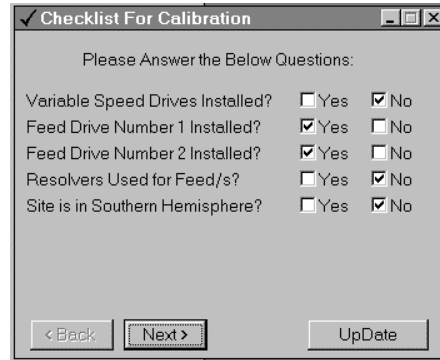

1. Insure that the software is polling the controller. (See *Activating Polling*)
2. Select the *Antenna Control* screen as active.
3. From the *Antenna Control* menu, select Calibrate and then Checklist.

Verifying Motion

Before attempting any calibration of the antenna, the installer/operator should verify that the antenna motion is correct for each axis. Although each axis is equipped with electrical limit switches that are designed to stop the antenna motion when a limit is reached, if the antenna motion is in the direction opposite the normal, these limit switches will not stop the antenna motion and damage could occur. To verify the proper motion of the antenna, perform the following steps.

1. Position a lookout person to observe the actual motion of the antenna and establish a means of communication between the antenna operator and the lookout.
2. Using the Jog Buttons on the *Antenna Control*, jog the axis in the up direction (right Jog Button.)
3. Verify that the position indicator value increases (in a positive direction.)
4. Verify that the Lookout observes motion in the direction indicated by the following table.

Antenna Motion for Each Axis

Axis	Button	Indicator	Motion
Azimuth*	Right	Increase	Clockwise
Azimuth*	Left	Decrease	Counter-Clockwise
Elevation	Right	Increase	Up toward Zenith
Elevation	Left	Decrease	Down toward Horizon
Feed 1/2	Right	Increase	Clockwise
Feed 1/2	Left	Decrease	Counter-Clockwise

* In southern hemisphere installations; when the indicator increases past 359.99, it will go to 0 and when it decreases past 0 it will go to 359.99.

Note: The references for clockwise/counter-clockwise are as follows:

Azimuth - as view from above antenna looking down

Feed 1 - as viewed from behind antenna looking toward satellite

Feed 2 - as viewed from behind the sub-reflector looking toward reflector

If the motion of the antenna appears correct but the indicator changes in the opposite direction, the *Alternate Direction* parameter in the *Axis Setup* will need to be changed. (See *Axis Setup*.) If the Axis Motion is reversed, then there is most likely a problem with phase reversal in the motor wiring.

Checking Limit Switches

Before attempting to perform any antenna calibration, the limit switches for each axis should be checked for proper operation. To check the limit switch you will need one person to monitor the *Antenna Control* screen and one person to physically activate each switch. Limit switch status is displayed on both the *Antenna Control* screen and the *Fault* screen. To check the proper indication of the switch:

1. Depress the limit switch and hold it for a few seconds.
2. While the switch is depressed, observe that the screen area for the limit switch changes to yellow.

Note: If the screen area for the selected limit switch remains white or turns red, or if another limit switch screen area changes color, then there is a problem with the limit switch wiring.

The above procedure checks to see that the limit switches are providing the correct indication to the Controller. This does not however verify that the switch will stop the antenna motion in the direction of the switch. To check for proper operation of the switch you can do either of the below:

- A1. Manually depress the limit switch and with it depressed, try to jog the antenna in the direction of the limit switch. The antenna axis should not move. If it does, STOP the antenna IMMEDIATELY!
- A2. With the limit switch still depressed, jog the antenna in the direction opposite of the limit switch. The antenna axis should move.

or

- B1. Slowly move the antenna to the limit switch until it is depressed and try to jog the antenna in the direction of the limit switch. The antenna axis should not move past the limit switch. If it does, STOP the antenna IMMEDIATELY!
- B2. Jog the antenna in the direction opposite the limit switch. The antenna axis should move away from the limit switch.

Note: The switches are designed to allow the antenna to back-out of the limit. Antenna axis motion in the direction of the limit switch should stop anytime the limit switch is depressed. Motion in the opposite direction from the switch should not be inhibited when the switch is depressed.

Calibrate Look Angle

To Calibrate the Look Angle to a specific satellite. You should follow these Steps:

1. First verify that the antenna motion is correct for all axis's (Az, El, etc.) . See *Verifying Motion*.
2. Make sure that All Limit Switches are functioning properly. See *Checking Limit Switches*.
3. Locate a known satellite near the center of the antenna's Azimuth range.
4. Calculate the predicted Look Angle to the selected Satellite.
5. Peak the antenna for maximum receive signal.
6. Enter the Predicted Pointing Angles into each axis *Move* text box on the *Antenna Control* screen.
7. From the *Antenna Control* Menu, Select first: Calibrations, and then Calibrate Look Angle.
 Note: A Caution message should appear to let the user know that the angle readouts will change.
8. Select the Yes button to continue the calibration.

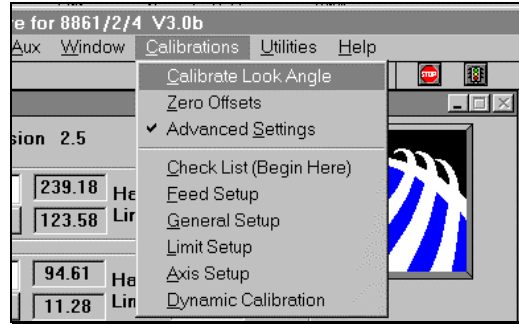

Results:

After a few seconds messages will appear in the *Antenna Control* message area. These messages indicate changes being made to the controller's *Axis Parameters*. When the messages have stopped displaying, the axis readouts should slowly settle to the values entered into the *Move* text boxes. The Azimuth and Elevation values should settle to within 0 to 0.02 degrees of the entered values. The Feed values should be within 0 to 1 degree of the entered values.

Problems:

If the angle values do not settle within the above ranges, repeat step 7. If repeated attempts do not result in readouts within the above mentioned ranges, there could be a problem with which ever axis/'s does/do not settle properly.

General Setup

General Setup parameters are used to configure the 8861/2 for various options such as Variable Speed Drives; Southern Hemisphere; or Emergency-Stop Relay. These settings can be uploaded from a file contained in the \CAL sub-directory or can be set manually from the General Setup screen. There are typically only four different configurations which should cover most installations. These files are named:

<u>Filename</u>	<u>Configuration</u>
8861NLAT.DAT	8861 Northern Latitude
8861SLAT.DAT	8861 Southern Latitude
8862NLAT.DAT	8862 Northern Latitude
8862SLAT.DAT	8862 Southern Latitude

To upload the 8861/2 with one of these standard configurations perform the following steps:

1. Activate Polling for the 8861/2 Controller. (See *Activating Polling*)
2. From the Antenna Control menu select File and then Restore Setup.
3. Change to the \CAL sub-directory to locate one of the above files.
4. Select the file to load and then the OK button.

The file should load after a short while and messages will display the current status of the upload.

While these four files should cover most standard installations, there may be need to modify some of these initial settings. The *General Settings* screen will display the current settings and allow you to modify these. Most settings are TRUE/FALSE indicated by a check box where: checked = TRUE. Temperature settings are either in decimal or degrees Celsius. To change the setting do the following:

1. Enter the new value into the text box or click on the check box.
2. The setting will highlight in cyan. For text boxes, press the <Enter> key.
3. Select the Yes button from the message prompt or the No button to cancel.

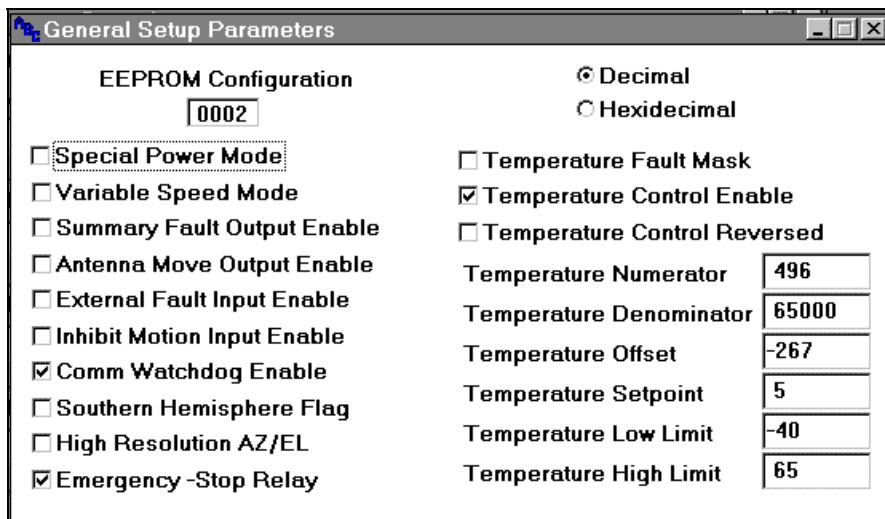

The following is a list of the General Setup Parameters:

Special Power Mode	<i>used for DC motors only</i>
Variable Speed Mode	<i>8862 only</i>
Summary Fault Output Enable	<i>output a contact closure on Aux Out 0 during fault condition</i>
Antenna Move Output Enable	<i>output a contact closure on Aux Out 1 during antenna moves</i>
External Fault Input Enable	<i>enable External Fault input on Aux In 0</i>
Inhibit Motion Input Enable	<i>enable Motion Inhibit input on Aux In 1</i>
Comm Watchdog Enable	<i>enable the watchdog timer for controller communications</i>
Southern Hemisphere Flag	<i>used for site installations below the equator</i>
High Resolution AZ/EL	<i>used for 4:1 high resolution resolvers</i>
Emergency-Stop Relay	<i>select whether Emergency-Stop relay is installed (typically on 8862)</i>
Temperature Fault Mask	<i>mask the temperature fault</i>
Temperature Control Enable	<i>select whether temperature control for heater/fan is used</i>
Temperature Control Reversed	<i>reverses the action of the temperature control relay</i>
Temperature Numerator	<i>used to set scaling for temperature sensor</i>
Temperature Denominator	<i>used to set scaling for temperature sensor</i>
Temperature Offset	<i>offset for the temperature reading</i>
Temperature Set point	<i>sets the temperature at which cooling/heating comes on</i>
Temperature High Limit	<i>limit for high temperature alarm</i>
Temperature Low Limit	<i>limit for low temperature alarm</i>

Axis Setup

The *Axis Setup* screen is used to set parameters for each axis of the antenna. This screen displays and allows the operator to change the axis parameters for the axis selected with the Axis option button. In most cases it should not be necessary to change these settings, with the possible exception of the *Alternate Direction* checkbox. Changing the parameters on the Axis Setup screen is similar to changing the General Setup parameters. Below is a listing of the Axis Setup parameters:

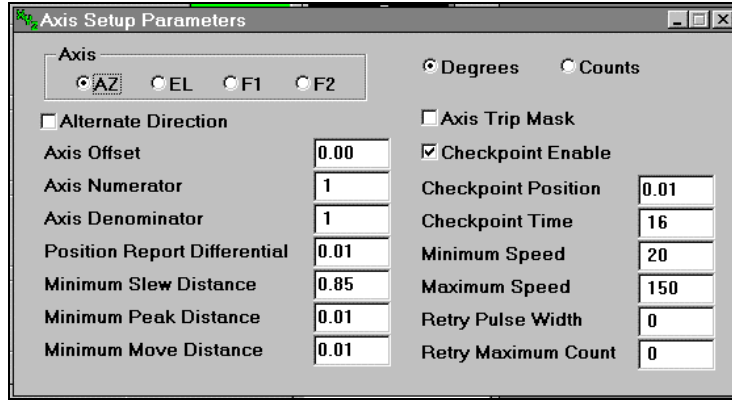

Alternate Direction	<i>used to correct backward reading indicator</i>
Axis Offset	<i>offset the axis readout</i>
Axis Numerator	<i>set scaling for axis readout (data pots only)</i>
Axis Denominator	<i>set scaling for axis readout (data pots only)</i>
Position Report Differential	<i>threshold for reporting axis movement</i>
Minimum Slew Distance	<i>minimum movement required to activate high speed movement (VSD)</i>
Minimum Peak Distance	<i>minimum movement required to activate low speed movement (VSD)</i>
Minimum Move Distance	<i>minimum differential required for a Move command.</i>
Axis Trip Mask	<i>mask the axis overload trip fault for breakers without trip contacts</i>
Checkpoint Enable	<i>enable axis checkpoint according to position and time</i>
Checkpoint Position	<i>number of position counts used by the checkpoint feature</i>
Checkpoint Time	<i>time (in 250ms increments) for the checkpoint feature</i>

Minimum Speed	<i>minimum percent of base motor frequency used by VSD</i>
Maximum Speed	<i>maximum percent of base motor frequency used by VSD</i>
Retry Pulse Width	<i>the pulse width (in 4ms increments) for retry pulse</i>
Retry Maximum Counts	<i>the maximum number of retries to move a stuck actuator</i>

Note: The above is not the complete listing of axis parameters used by the 8861/2 controller. Other parameters such as: Limits; Axis Installed; and Stopping Distances are accessed using screens other than the Axis Setup screen.

Feed Setup

The feed setup is used to configure the feed/s that is/are installed on the antenna. Circular polarized feeds do not have drive motors so they do not require setup. Antennas configured for linear polarization can have either 1 or 2 feeds which can utilize either data pots or resolvers to report position to the controller. Since resolvers are coupled 1:1, feeds that utilize resolvers do not normally require a calibration other than to set the axis offset parameter so the angular rotation reading is correct. Feeds with data pots, on the other hand, can vary widely and need to have a scaling factor calibrated so their angular position can be accurately reported. Once configured, feed calibration consist of primarily two steps with an optional third step to determine stopping distances (*Dynamic Calibration.*)

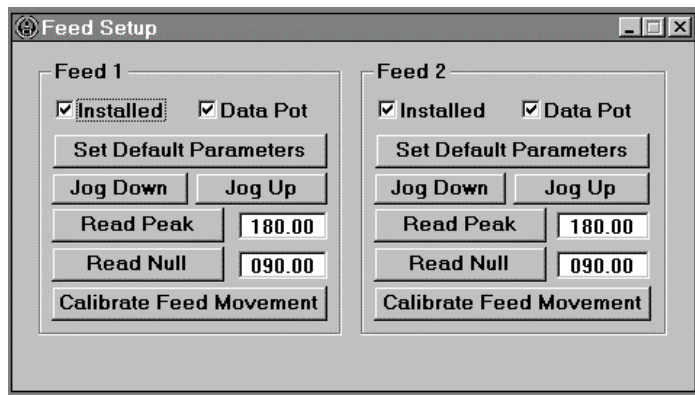

The first two steps determine the range of motion (limit to limit) and the scaling factor of the data pot. These can be done a variety of ways depending on the desired accuracy and/or personal preference. The software provides a variety of tools that can be used to calibrate the feeds. Some are fairly simple to use and provide a limited degree of accuracy, while other require more effort but can result in higher degrees of accuracy.

In order for the automated procedure to work, the following installation guidelines should be followed:

DETAILED OPERATION

1. Locate the feed flange for the vertical polarization (TX or RX) and position it such that the short dimension of the waveguide is perpendicular to the antenna foundation. An inclinometer will help to determine this position.
2. Make the necessary adjustment so that the feed can freely rotate a minimum of 90 degrees, either side of the position setting in step 1, without activating a limit switch.
3. Adjust the limit switches for a minimum feed travel of 180 degrees and a maximum of 200 degrees.

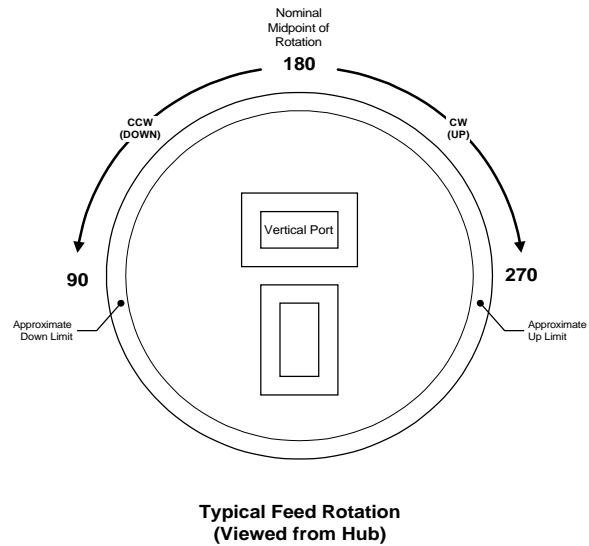

Note: If the above adjustment can not be achieved with the feed flange selected in step 1, then select the other feed as the vertical feed, making note of the change.

The above steps are performed in order establish a reference for feed rotation that allows polarization angles to be calculated for any given satellite. Without such a reference, it might be difficult to determine which pol the antenna is receiving on or transmitting to. They are not an absolute necessity but are highly recommended.

Procedure:

With the above steps considered, the feed can now be calibrated. Be sure to verify both the direction of motion and the proper functioning of the limit switches. Having done all of the above, proceed as follows:

1. Move the feed to the approximate center of it's movement range between the limit switches.
2. On the Feed Setup screen select *Set Default Parameters* for the desired feed.
3. Check the position readout (after settling) for the following:

<u>Transducer</u>	<u>Center Reading</u>
Data Pot	90-270
Resolver	120-240

Note: The nominal reading for either transducer is 180. If the reading is not within the above range, then it may be that the installed position of the

transducer is wrong or that the transducer is faulty. Check for these and correct as needed.

4. Determine a method of measuring 90 degree movement in the feed. (inclinometer preferred*)
5. Click either the Read Null or Read Peak button to record the angular reading of the Null/Peak.
6. Rotate the feed 90 degrees (measured WITHOUT the use of the position indicator on the Control screen.)
7. Click either the Read Peak or Read Null button (other than the one pressed in step 4)
8. Click the Calibrate Feed Movement button to start the calibration.
9. Read the caution message carefully and if everything checks OK then select Yes to continue.
10. The calibration routine should move first to the low limit then to the high limit.
11. Upon completion, hard limits should be updated and the feed should stop at the up limit.

Note: While the feed calibration routine is running, you should let it complete before attempting any other operation using the computer. This can corrupt the calibration data. If you need to stop the antenna, use the Stop button. You will have to redo the calibration if it was stopped before completion.

- * If an inclinometer is not available, an alternative might be to monitor a downlink carrier from the satellite and rotate the feed while observing the peak and null of the signal. The peak and null should occur 90 degrees offset from each other. The peak and null positions of this signal could then be read in order to determine 90 degrees of rotation. Due to a variety of factors this method is at best an approximation and not as accurate as the use of an inclinometer or other similar measuring device.

If The above calibration is successful, you may want to calibrate the stopping distances (otherwise referred to as *Dynamic Calibration*.) While Dynamic Calibration is not essential, it can result in improved performance when moving between satellites.

Other Methods of Feed Calibration

The above procedure is based on the feed center being at 180 degrees on the position indicator. If this position does not agree with the end user's requirements, the reading can be changed by adjusting the axis values using the *Axis Setup* Screen. In addition, The *Calibrate Look Angle* method can be used to set the offset. If the offset axis values are changed from those originally set during the calibration routine. It is recommended that the *Limit Set* screen be used to find new feed limits. Using the variety of screens available, the user can

fine tune the feed calibration to his own requirements. When ever the user is satisfied with the performance, he should save the settings to a file so the data can be restored if it becomes corrupted in any way.

Limit Setup

Setting the axis limits is a fairly simple procedure but care should be taken to first insure that the axis motion is correct and the limit switches are working properly. If the *Find Hard Limits* routine is run without proper precautions, it could result in damage to equipment or injury to personnel. This routine moves first to the low limit and then to the high limit. Depending on the speed of the antenna, this could take a few minutes or more than an hour. Be sure when running this routine, there is sufficient time in the schedule for the routine to complete. To automatically locate the hard limits, do the following:



1. Open the *Limit Setup* screen.
2. Select the desired axis option button.
3. If Soft Limits are not set to maximum values then set them.*
4. Click on the *Find Hard Limits* button.
5. Read the Caution and if all is OK then select Yes to continue.
6. Allow the routine to complete before attempting any other operations using the computer.

When the routine is complete, the hard limits will update and the antenna will stop at the up limit.

Note: Both Hard Limits and Soft Limits can be set manually by typing the new value in the appropriate text box and pressing <Enter>.

* Maximum Limits are: 0.01 to 359.99 (Azimuth in Southern Hemisphere are:180.01 and 179.99)

Dynamic Calibration (optional)

It has been found, that the Dynamic Calibration routine, used with past calibration software, can adversely effect the performance of tracking. For that reason, this version of software allows the user to set “Dynamic Default” parameters that have been found to work better with larger antennas. If the user intends to use the tracking features of the 8860, it is highly recommended that these defaults be used instead of performing the normal Dynamic Calibration. If the user wishes to perform the Dynamic Calibration, then he should be advised that tracking performance may be degraded.

Dynamic Calibration is done on the 8861/2 for the purpose of setting the stopping distances for each axis drive. Each axis' movement range (limit to limit) is divided into 8 segments. The dynamic calibration measures the time required to stop the antenna's motion in each of these 8 segments. Stopping distances are measured for both directions of movement. During the calibration process, the measured results are uploaded into the 8861/2 controller EEPROM. This uploaded data is stored in a table that the controller uses to determine when to issue the command to deactivate the drive relay/s. The table values represent the amount that the antenna should coast after the relay deactivation command is sent. These values will vary depending on the speed of the motors and a number of other factors.

The calibration software allows for three methods of changing the data in the tables. The data can be changed: manually; using the Quick Calibrate method; or using the Calibrate All Stops method. Each method has advantages and disadvantages.

Quick Calibration

The quick calibration method is the fastest and easiest method of calibration. This method moves the antenna to the approximate center of the axis range, and measures the stopping distance in both directions. These two measurements are then loaded into all 8 table segments for both directions. This method assumes that the stopping distances are fairly constant across the range of motion. This assumption may or may not be true depending on a number of factors. If the antenna is operated mostly in a position near the center of its travel, this method should provide fairly good performance.

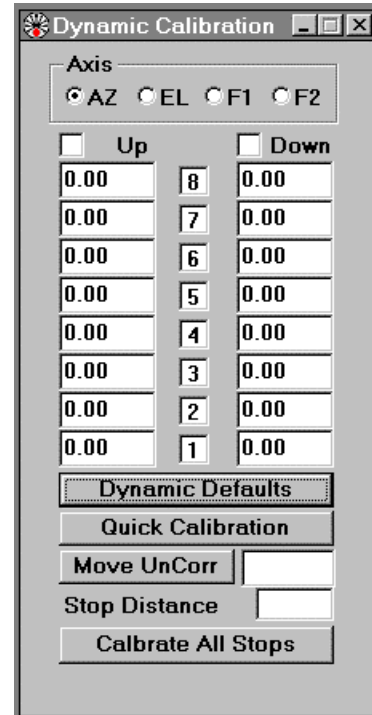

Calibrate All Stops.

If the antenna is to be used at a location where it is moved quite often between satellites that are several degrees apart, then this method of calibration should be used. This method assumes that the hard limits have been set properly and that they represent the full operating range of each axis. This method will first move the axis to the down limit and then up to each 8 segments to measure stopping distance for each. After measuring the up direction stopping distances, it then reverses the motion of the antenna and measures each of the down stopping distances. Depending on the speed of the antenna and the range between limits, this method can take a while to complete.

Manual Calibration

For those who have the time and patience, the antenna stopping distances can be measured individually for each segment and the data entered in manually. This method allows the operator to experiment with stopping distances and to average the results of several moves to each sector. Due to the time required for this type of calibration, it is not recommended for normal antenna use and is only useful for R&D purposes.

ADVANCED CALIBRATION PASSWORD

In order to bypass the Calibration Checklist and/or to access certain parameters not normally requiring change, a password is needed. This password is not a security feature and is only intended to limit access to novice users. The password is hard coded in the software and cannot be changed without modifying the source code and recompiling. The password is: **FULL_ACCESS**. The password is not case sensitive but does require the “_” (underscore character) as part of the password.

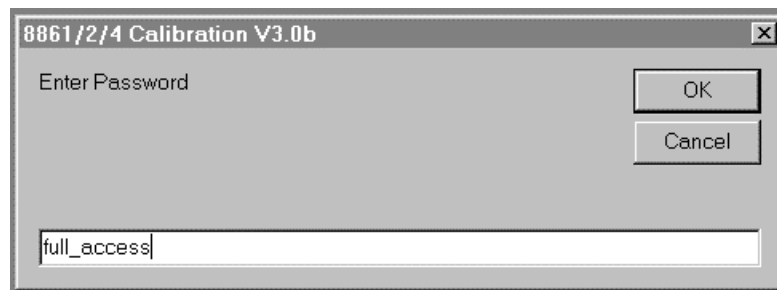

SECTION 3 UTILITIES

INTRODUCTION

Utilities are features added to the Calibration Software that provide support functions that assist in setting up the antenna control system. While these utilities are not essential to calibrating the 8861/62/64 APC, they provide convenient means for the user to perform task that would otherwise be more difficult and time consuming. Below is a list of these utilities along with a brief description of their purpose:

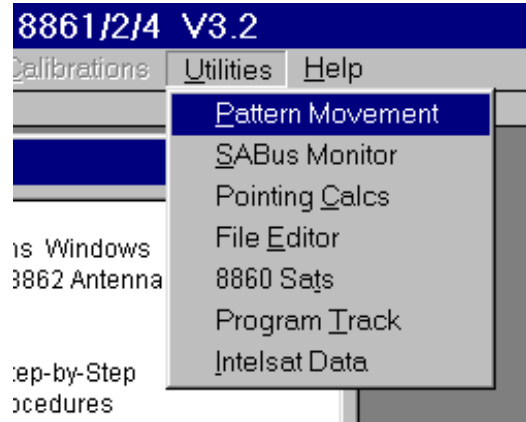

<u>Utility</u>	<u>Description</u>
Pattern Movement	Used to slew the antenna during pattern measurements
SABus Monitor	Used to monitor the SABus communications between the PC and the 8860/8861/8862/8864
Pointing Calcs	Used to calculate the pointing angles from a given site location to a geosynchronous satellite
File Editor	A text based editor for modification of ASCII files
8860 Sats	Used to upload and/or download satellite tables to/from the 8860
Program Trak	Used to upload and/or download program track data to/from the 8860
Intelsat Data	Used to upload and/or download Intelsat data to/from the 8860

Pattern Movement

The Antenna Pattern Movement utility is used to assist in setting up the movement parameters needed to perform Antenna Pattern measurements. The antenna is first peaked on the satellite that will be used to perform the measurements. The user then enters the parameters that will be used to move the antenna the amount required for pattern measurement.

To use the Pattern Movement utility during pattern measurement:

1. Peak the antenna on the satellite
2. Click the **Read Peak** button
3. Select either **Az** or **El** as appropriate

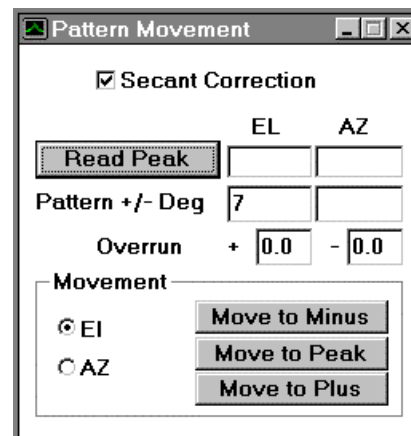

Note: when doing Azimuth, the Secant correction should be used so that corrected movement is calculated.

4. Enter the movements value required for pattern measurement
5. Click the **Move Minus** button to move to the start point for the pattern.
6. Click the **Move Plus** button to start movements for pattern measurement
7. After concluding the measurement, click **Move Peak** to return to the peak position.

If during measurement, the movement of the antenna does not appear to be synchronized with the measurements, try entering some overrun values.

SABus Monitor

The SABus Monitor utility is used to check the SABus communications between the computer and the controller (or other SABus devices). It provides a useful tool for troubleshooting and for R&D purposes. This utility can be used to monitor the communications between the 8860 and the 8861/8862 Positioner. When in monitor mode, communications is delayed in order to allow for human observation. Because of this, monitor mode should be avoided during calibration routines. To test single command responses, the monitor mode should be disabled and polling should be deactivated.

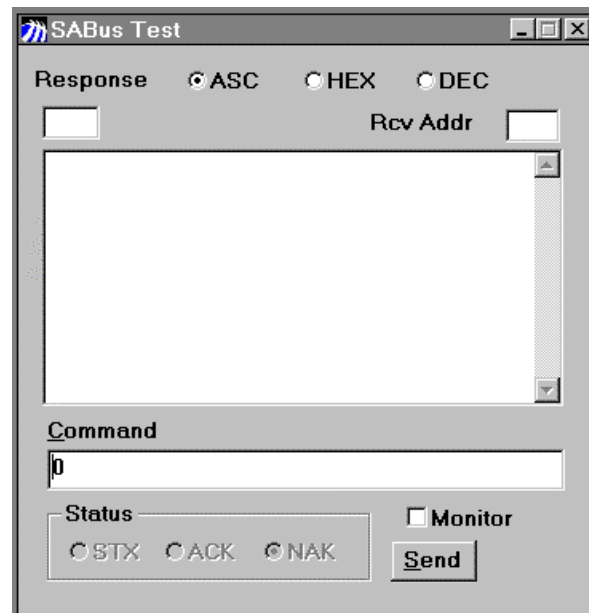

Pointing Calculator

The Pointing Calculator is used to calculate the pointing angles from a particular site to a particular satellite. It uses the Site Latitude, Site Longitude, Site Altitude, and Satellite Longitude to determine Azimuth; Elevation; and Polarization angles. Satellite Names and Longitudes are loaded into the calculator from text files which contain the: Name; Longitude; and east/west location from the prime meridian. Site coordinates can be entered manually and can be saved to disk. Once site coordinates are saved, they are automatically reloaded the next time the program is started. The Pointing Calculator can also generate Satellite Tables that are formatted for upload into the 8860 Antenna Tracking Controller. Once pointing data is calculated, it can be transferred to the Antenna Control Screen for a **Move All** command or to **Calibrate Look Angle**. When the Pointing Calculator is the active window, the main menu is replaced by the pointing calculator menu.

Site Parameters

When using the pointing Calculator, it is important that the site parameters are entered correctly. The Latitude and Longitude can be entered as Decimal or in Degrees, Minutes, Seconds. When entering the values in Decimal, enter the value in the Degrees text box only. The program will automatically convert it to Minutes and Seconds. Be sure and select the proper hemisphere for both Latitude and Longitude. The Altitude entry is optional. If you know the actual site altitude it can help improve the accuracy of the calculations. If you don't know the altitude, set the value to zero (0).

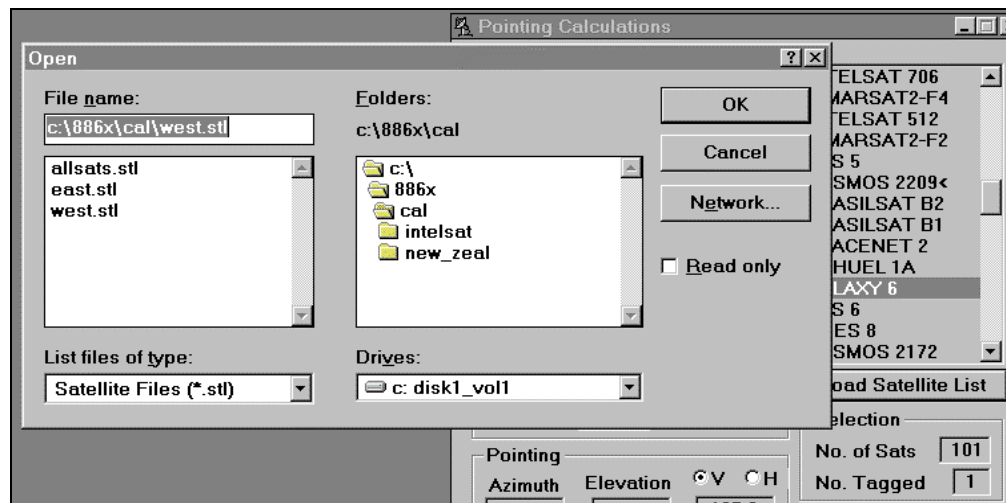
Satellite List

When the Calibration Program is installed, it loads a list of known satellites that were current as of July, 1997. These list are contained in the directory :886X\CAL. These file are in ASCII format and can be edited to add or delete satellites. The files will have an extension name of: .STL. The user can create his own custom list if desired by using the File Editor utility (or any other text editor) and opening one of the included files and adding or deleting as required. The new file can then be save under any appropriate file name as long as you include the extension .STL. To us the satellite list with the Pointing Calculator:

1. Click on the **Load Satellite List** button
2. From the directory dialog, locate the file (usually under C:\886X\CAL)
3. Double-click the filename for the satellite list.

The file will load, and the SATLIST display will show the names of the satellites loaded. You can then scroll through the list to locate the satellite of interest. When you click on the satellite name, the satellite parameters will show up in the appropriate boxes, and the pointing angles will be calculated and displayed.

Satellite Parameters

The Satellite Parameters can be viewed for a selected satellite by clicking on the satellite name in the SATLIST box. If the satellite in question is not on the list, the user can enter the parameters manually, and then click the **Calc** button to calculate the pointing angles.

Note: this information is not saved or added to the current list. To add a satellite, the file will need to be edited.

Table Creation

The pointing calculator can be used to create a table of satellites for uploading into the 8860 Antenna Tracking Controller. By holding down the CTRL key on the computer keyboard, the user can scroll through the list of satellites and “tag” the ones he wants to add to the 8860 table. Once the satellites are tagged, do the following:

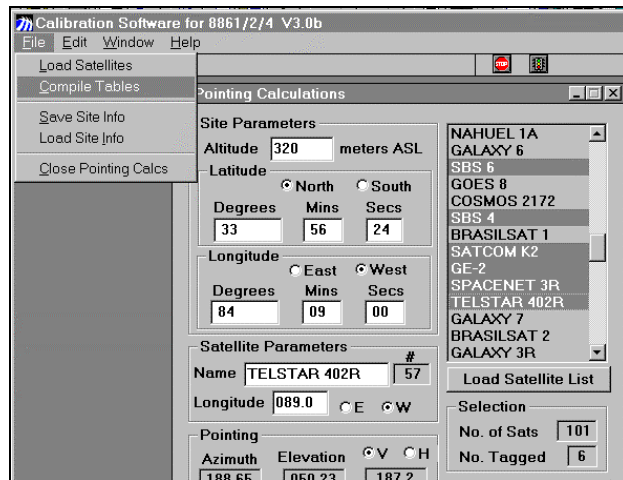

1. From the Menu, select File and then Compile Tables
2. After a short while the File Editor will be displayed with the new table loaded
3. Use the editor to check and edit the table if required.
4. From the Menu select File and the Save As
5. Give the file a name being sure to add the .TBL extension.

This new file can then be utilized by the **8860 Sats** utility for upload to the 8860.

File Editor

ID#	Satellite	Azimuth	Elevation	Feed 1	Feed 2	Mode	Inclination
01	SBS 6	162.38	049.12	165.5	194.50	0	00.00
02	SBS 4	167.50	049.85	169.7	190.30	0	00.00
03	SATCOM K2	180.27	050.57	180.2	179.80	0	00.00
04	GE-2	181.34	050.57	181.1	178.90	0	00.00
05	SPACENET 3R	185.10	050.45	184.2	175.80	0	00.00
06	TELSTAR 402R	188.65	050.23	187.2	172.80	0	00.00
07	GALAXY 3R	198.96	048.88	195.6	164.40	0	00.00
08	TELSTAR 5	202.24	048.22	198.3	161.70	0	00.00
09	TELSTAR 302	202.72	048.12	198.7	161.30	0	00.00
10	GALAXY 4	205.42	047.47	200.8	159.20	0	00.00
11	SPACENET 4	208.50	046.62	203.3	156.70	0	00.00
12	GSTAR 4	214.46	044.63	208.0	152.00	0	00.00
13	GSTAR 1	214.46	044.63	208.0	152.00	0	00.00

The File Editor utility is a simple text editor that can be used to view and/or edit files that are used by other parts of the software. The file editor can be started by clicking the Editor Icon on the Tool Bar, or by Clicking on the File Editor selection under the Utilities on the main menu. When the Editor is the active window, the main menu is replaced with the editor menu. The following file extensions are used by the Calibration Software:

- *.STL Satellite lists with names and longitude data
- *.TBL Satellite Tables formatted for upload to 8860
- *.DAT 8861/62/64 Setup and Calibration data files
- *.PTD Program Track Data file

8860 Sats

The 8860 Sats utility is used to download or upload Satellite Tables from and/or to the 8860 Antenna Tracking controller. The tables are stored as text files and can be edited using the **File Editor** utility. Satellite tables can be created initially using the **Pointing Calcs** utility. When the Calibration Software is running and the PC is connected to the 8860 you can download the satellite tables by clicking the **DownLoad** button. After the table is downloaded, you can view and/or edit the table by clicking the **Edit** button. If you want to make changes, use the editor to make the changes and the save the file. You will need to load the new file before attempting to upload the changes to the 8860. To load a file into the utility:

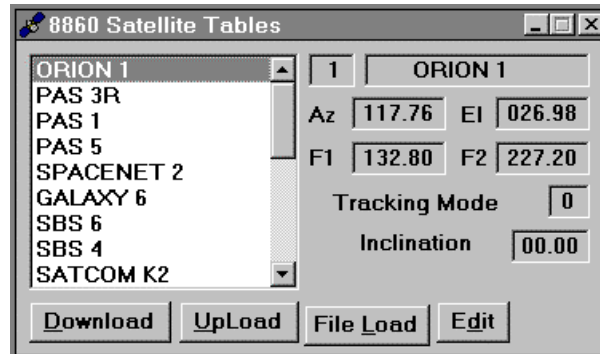

1. click on the **File Load** button
2. locate the file with the .TBL extension
3. double-click on the file name

After a short while, the file will be loaded into the utility and ready for upload to the 8860. To upload the file to the 8860, just click on the **Upload** button. It will take a few seconds for the file to upload, so be patient. After the upload is completed, check the 8860 to see if it received the data.

Note: The 8860 checks each entry into the table to see if it is valid. If the satellite pointing angles are outside the limits for any axis (Az, El, F1, F2) it will not accept the data. If some or all of the tables do not upload, check the file for invalid parameters.

Program Track

The Program Track utility is used to download or upload tracking values from and/or to the 8860 Antenna Tracking controller. Program Track Files can be created for upload to the 8860 in the following text format:

```
mm-dd-yyyy
hh:mm:ss
tttt, xxx.xx, +/-y.yy
...
```

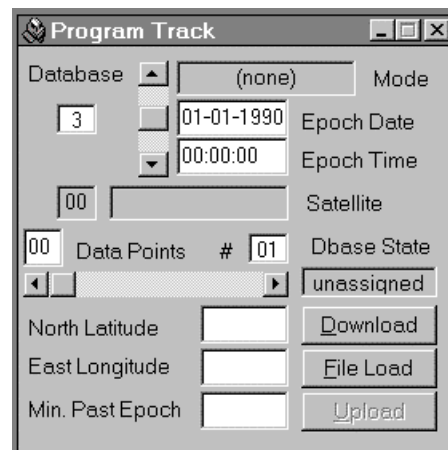

Where:

- mm-dd-yyyy = Epoch Date (Month-Day-Year)
- hh:mm:ss = Epoch Time (Hour:Minute:Second)
- tttt = sidereal minutes past epoch (0000 to 1436)
- xxx.xx = satellite east longitude (000.00 to 359.99)
- +/-y.yy = satellite north latitude with sign (-9.99 to +9.99)

There can be a maximum of 96 lines after the Epoch Time with each representing a satellite position. Be sure to include commas to delimit the position data. The file should be saved with the .PTD filename extension.

example file: TRACK.PTD

```
09-03-1997
10:20:30
0000, 283.00, +0.00
0015, 282.99, +0.23
0030, 282.98, +0.45
0845, 283.01, - 0.78
```

Intelsat Data

The Intelsat Data utility is used to check and/or upload Intelsat parameters to the 8860 Antenna Tracking Controller. This utility can be used to extract the Intelsat pointing parameters from standard messages which are available via the Internet. The operator should be aware that uploading new Intelsat parameters will change any current database in the 8860 and if the 8860 is currently tracking an Intelsat satellite, tracking will be halted.

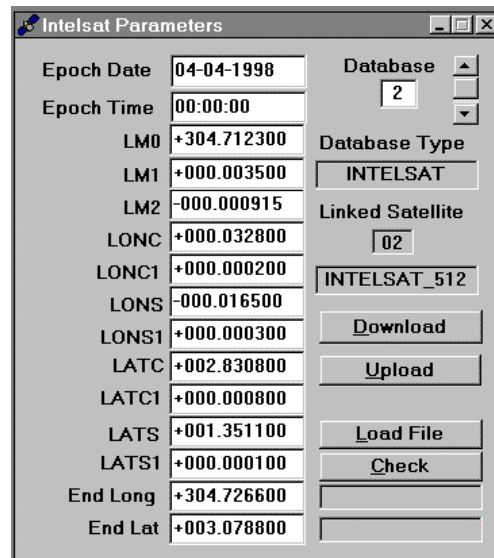

To utilize an Intelsat message, the user must download it from the Intelsat web site, into a text format, using software such as Netscape or Internet Explorer. Once the message is downloaded. The Intelsat utility can load and parse the message for preparation to upload to the 8860. To prepare for uploading the message:

1. Access the Intelsat Web site and save the ephemeris message as a text file.
2. If the 8860 is currently in tracking mode, disable the tracking.
3. Start the Calibration Software

4. From the Main Menu Click *Utilities* and then *Intelsat Data*.
5. Select the proper Database number (1-5) that was previously setup for Intelsat tracking and click the **Download** button.
6. The display should indicate the Database type as INTELSAT. If it does not, repeat step 4.
7. Click on the **File Load** button
8. Locate the file saved in step 1
9. double-click on the file name.
10. The file should load and the various parameters should be displayed. The values underneath the Check button should match The End Long and End Lat values from the message file. If the values match, the data is ready for uploading to the 8860.
11. Click on the **Upload** button
12. A warning message will appear to let you know the database will be changed. To continue select **Yes**.

After the Intelsat parameters are uploaded, you will need to exit the Calibration Software, or turn the polling off, in order to restore the 8860 to tracking mode.

Sample Intelsat Message(Downloaded from : www.intelsat.com/IOC/ephemeris)

ROUTINE

FROM: INTELSAT WASHINGTON DC

TO: ALL STATIONS OPERATING AT 304.50 DEG EAST

SUBJECT: ELEVEN PARAMETER EPHEMERIS FOR INTELSAT 512/304.50
DEG E

EARTH STATIONS PLEASE ON-PASS TO YOUR ADMINISTRATION

WEEKLY 11-PARAMETER DATA 980404

THE 11 PARAMETER EPHEMERIS AND EPOCH PREDICTING THE SPACECRAFT
MOTION ARE PROVIDED BELOW.

PLEASE ENTER THIS DATA INTO THE EPHEM.DAT FILE

YEAR MONTH DAY HOUR MINUTE SECOND
98 04 04 00 00 00

THE EPHEMERIS VALUES ARE:

LM0	LM1	LM2
DEG. E	DEG/DAY	DEG/DAY/DAY
304.7123	.0035	-.000915 (MINUS)

LONC	LONC1	LONS	LONS1
DEG. E	DEG/DAY	DEG. E	DEG/DAY
.0328	.0002	-.0165 (MINUS)	.0003

LATC	LATC1	LATS	LATS1
DEG. N	DEG/DAY	DEG. N	DEG/DAY
2.8308	.0008	1.3511	.0001

THE NOMINAL ORBITAL LOCATION FOR THIS SATELLITE IS 304.50 DEG. E

THE PREDICTED SATELLITE LONGITUDE AND LATITUDE AT 170 HOURS AFTER
EPOCH ARE 304.7266 DEG. E. AND 3.0788 DEG. N.BEST REGARDS
MANAGER IOC

REVISION HISTORY

January 10, 2002 plo V3.0

- Added command 44 Hex to read the high resolution (20-bit) Azimuth and Elevation values.

March 10, 1994 pcl V2.2-V2.4 (Document Change Only)

- Added note to command 64 for V2.4 firmware.
- Corrected message description for command 68-6F.
- Added note to command 59.

April 5, 1993 pcl V2.2

- Added command 43, Enable/Disable comm guard mode, which forces a controller restart approximately one minute after the last valid message is received.
- Added command PAL output state reporting to command 65.

January 24, 1993 pcl V2.1

- Split the position reporting differential and minimum move distance into two separate parameters. The position reporting differential is now axis parameter 0x0d. The minimum move distance remains parameter 0x10.
- Added parameter 0x16 - position retry pulse width, in clock ticks.
- Added parameter 0x17 - maximum number of position retries.
- Added command 42 - enter/exit maintenance mode - allows installer to bypass position checkpointing.

April 24, 1992 pcl V2.0

- Revised description of operating modes to include discussion of variable-speed controllers. Added speed comment to all move commands.
- Command 31 - power-up-flag is now configuration-change-flag and is asserted after the change speed command as well as after exit from setup mode.
- Command 34 - added byte 6 containing e-stop, phase-loss, and drive fault bits.
- Changed command 3C from auxiliary inputs and outputs 1 and 2 to 0 and 1 respectively. On variable-speed controllers, there are also auxiliary input 2 and auxiliary output 2.
- Added command 41 - change axis speed.
- Added southern hemisphere note to command 51.
- Changed command 62 to include bits for e-stop sense and aux. input 2.
- Command 65 - added byte 3 containing bits for drive reset, e-stop control, and AZ, EL deceleration control.
- Added command 6A for testing analog speed outputs.

October 16, 1991 pcl V1.3

OPERATIONAL COMMANDS

<u>ASCII</u>	<u>HEX</u>	<u>FUNCTION</u>
'0'	30	Device ID Query
'1'	31	Status Query
'2'	32	Extended Query
'3'	33	Axis Position Query
'4'	34	Fault Query
'5'	35	Hard Limit Query
'6'	36	Soft Limit Query
'7'	37	Move All Axes
'8'	38	Move Axis
'9'	39	Move by Time
','	3A	Clear Status Change Flag
','	3B	Set Remote Lockout
'<'	3C	Aux I/O
'='	3D	Stop
'>'	3E	Reset Fault
'?'	3F	Restart APC
'@'	40	Reserved for Firmware Development
'A'	41	Change/Read Current AZ, EL Speed
'B'	42	Enter/Exit Maintenance Mode
'C'	43	Enable/Disable Comm Guard Mode
'D'	44	Read High Resolution (20-Bit) values for Azimuth and Elevation
'E'-'O'	45-4F	Not Used
'~'	7E	Comm Status Query/Clear

SETUP/CALIBRATION COMMANDS

<u>ASCII</u>	<u>HEX</u>	<u>FUNCTION</u>
'P'	50	Setup Mode Entry/Exit
'Q'	51	Read Axis - Uncalibrated
'R'	52	Move Axis - Uncorrected
'S'	53	Move by Time - Uncorrected
'T'	54	Read Stopping Distance
'U'	55	Set Axis Parameter
'V'	56	Get Axis Parameter
'W'	57	Set General Parameter
'X'	58	Get General Parameter
'Y'	59	Set Communications Parameters
'Z'	5A	Get Communications Parameters
'['-']'	5B-5F	Not used

FACTORY TEST COMMANDS

<u>ASCII</u>	<u>HEX</u>	<u>FUNCTION</u>
'\n'	60	Test Mode Entry/Exit
'a'	61	Test LEDs
'b'	62	Read Switches
'c'	63	Read Limits
'd'	64	Read Status
'e'	65	Test Relays
'f'	66	Read Channel
'g'	67	Test RDC
'h'	68	Test Reference
'i'	69	Test PWM (8862/64 only)
'j'	6A	Reserved
'k'	6B	Initialize EEPROM
'l'	6C	Reserved
'm'	6D	Reserved
'n'	6E	Reserved
'o'	6F	Test COP Timer, same as restart APC
'p'	70	Reserved for exclusive use by 8860
'q'-' '	71-7D	Not used

DESCRIPTION OF 8861/62/64 OPERATING MODES

- IDLE** All axis relays/drives are released and the antenna is not moving. While idle, the firmware monitors all installed axes for changes in position greater than the reporting differential and sets the summary change flag if this condition occurs. Also, the relay supply is turned off, and all installed limit switches are monitored for limit, shorted or open conditions, and reported accordingly. Several other resolver and analog test channels are also monitored for correct values.
- JOG** The Jog mode is initiated via the controller front panel switches and allows multiple axes to move at the same time. Each axis is sampled and controlled every 32 ms. The termination is time-based. Holding a switch in the on position presets a counter, which is allowed to count down when the switch is released. No stopping correction is applied to the turn-off time. For variable-speed controllers, each axis starts at low speed, then ramps up to high speed after about four seconds.
- SLEW** The Slew mode is initiated via the SAbus Move All command and allows multiple axes to move at the same time. Each axis is sampled and controlled every 32 ms. The termination is position-based. Each axis is driven to a position close to the commanded position and stopped. After all axes have reached the coarse stopping position, each axis is individually moved into commanded position using the peak mode. For variable-speed controllers, the coarse moves are made at high speed, followed by the fine moves at low speed.
- PEAK** The Peak mode is initiated following the slew mode to move a single axis into final commanded position. The selected axis is sampled and controlled every 4 ms. The termination is based on a linear interpolation of previously stored stopping distance correction values. The peak mode may also be initiated via the SAbus Move Axis command. For variable-speed controllers, the move is made at low speed.
- TIME** The Time mode is initiated via the SAbus Move by Time command and moves a single axis for a specified number of clock ticks, plus the time required for the axis relays to drop out. The selected axis is sampled and controlled every 4 ms. A command of zero causes the relays to be turned off immediately after turn-on has been detected. For variable-speed controllers, the move is made at low speed.
- MOVE-UNC** The Slew-Uncorrected mode is initiated via the SAbus Move-Axis Uncorrected command and moves a single axis to the specified coarse position. The move is not followed by a peaking cycle and is not corrected for stopping distance. For variable-speed controllers, the move is made at the high speed. The stopping distance is measured in preparation for a subsequent Get Stopping Distance command. This mode is intended to be used for dynamic calibration of the antenna and control system.
- TIME-UNC** The Time-Uncorrected mode is initiated via the SAbus Move by Time - Uncorrected command and is identical to the Time mode except that the stopping distance is measured in preparation for a subsequent Get Stopping Distance command. For variable-speed controllers, the move is made at the low speed. This mode is intended to be used for dynamic calibration of the antenna and control system.
- NOTE:** Due to hardware limitations, only the active transducer channels and limit switches are monitored while the antenna is moving in any of the modes (except

idle) described above.

Function	'0'	30	Device ID Query
Command	[addr]['0']		
Response	[addr]['0'][mmmmvv] where mmmm is the device model number 'controller' and vv is the software revision level with decimal point assumed 1 place right of the first digit.		

Function	'1'	31	Status Query
Command	[addr]['1']		
Response	[addr]['1'][n] where n is a single byte formatted as follows: b6: always 1 b5: EEPROM initialized (>V1.1) A value of 1 indicates that the EEPROM data was found to be invalid and was initialized to factory default values on power-up. b4: Power-Up Fault (>V1.1) This bit is set after a fault has been detected which forced an internal restart. (COP timer) b3: Configuration Change Flag This flag is set after the configuration (such as current azimuth or elevation speed) has changed. It is also set the first time this status is read after controller power-up, also set after a restart command. b2: Motion Flag A value of 1 indicates that the antenna is moving. b1: Status Change Flag A value of 1 indicates a change in status or position. This flag is cleared by the Clear Change Flag Command (3A). b0: Summary Fault A value of 1 indicates that a control or axis fault has been detected. This bit remains set as long as the fault condition exists or until cleared by the Reset Fault command (3E).		

Function	'2'	32	Extended Query
Command	[addr]['2']		
Response	[addr]['2'][n...][x...x] where n...n and x...x represent the limit data and axis position data, respectively, formatted as follows: byte 1: System Summary b6-b4: always 011 b3: Remote Lockout Flag A value of 1 indicates that remote positioning of the antenna is inhibited. b2: Local Mode Flag A value of 1 indicates that the controller Remote/Local switch is in the Local position. b1: Motion Inhibited (if enabled) b0: External Fault Input (if enabled)		

byte 2: AZ Limit Status
 byte 3: EL Limit Status
 byte 4: F1 Limit Status
 byte 5: F2 Limit Status

where each byte is formatted as follows:

b6-b4: always 011
 b3: Soft Limit Down
 b2: Soft Limit Up
 b1: Hard Limit Down
 b0: Hard Limit Up

bytes 6-9: AZ angle
 bytes 10-13: EL angle
 bytes 14-17: F1 angle
 bytes 18-21: F2 angle

All positions are reported as left-justified unsigned 16-bit integers. For example: 14adh --> 31h, 34h, 3ah,3dh.

The position values have calibration factors applied and represent 16-bit binary fractions of a circle. (i.e. 360 degrees divided into 65536 parts) If an axis is not installed, its value is returned as zero.

Function	'3' 33	Axis Position Query
Command	[addr] ['3'] [a] Returns the position of the specified axis, a, formatted as follows:	
	byte 1: axis select b6-b2 always 01100 b1-b0: axis select where 00 = AZ 01 = EL 10 = F1 11 = F2	
Response	[addr] ['3'] [x...x] where x...x is the position of the specified axis formatted as follows:	
	bytes 1-4: axis angle. The position is reported as a left-justified unsigned 16-bit integer. For example: 14adh --> 31h, 34h, 3ah,3dh. The position value has calibration factors applied and represents a 16-bit binary fraction of a circle. (i.e. 360 degrees divided into 65536 parts) If an axis is not installed, its value is returned as zero.	

Function	'4' 34	Fault Query
Command	[addr] ['4']	

Response [addr] ['4'] [f...f] where f...f is fault data formatted as follows:

byte 1: Control faults
 b6: always 1
 b5: eeprom power-up fault (> V1.1)
 b4: over temperature *
 b3: under temperature *
 b2: A/D converter fault
 b1: R/D converter fault
 b0: relay/power supply fault

byte 2: AZ Axis Faults
 byte 3: EL Axis Faults
 byte 4: F1 Axis Faults
 byte 5: F2 Axis Faults

where each byte is formatted as follows:

b6: always 1
 b5: Axis relay fault * (> V1.1)
 b4: Axis motion fault *
 b3: Axis upper limit failure *
 b2: Axis lower limit failure *
 b1: Axis backward operation *
 b0: Axis overload trip *

byte 6: Variable speed drive faults
 b6-b4: always 100
 b3: Emergency stop condition **
 b2: Phase loss or reversal fault
 b1: EL VSD fault *
 b0: AZ VSD fault *

* Indicates faults that are cleared by the Reset Fault command (3E).

** The E-Stop condition must first be corrected by closing the relay circuit, followed by a Reset Fault command (3E).

Function '5' 35 Hard Limits Query

Command [addr] ['5']

Response [addr] ['5'] [x..x]
 where x...x is the hard position limit data formatted as follows:

bytes 1-4: AZ lower hard limit
 bytes 5-8: AZ upper hard limit
 bytes 9-12: EL lower hard limit
 bytes 13-16: EL upper hard limit
 bytes 17-20: F1 lower hard limit
 bytes 21-24: F1 upper hard limit
 bytes 25-28: F2 lower hard limit
 bytes 29-32: F2 upper hard limit

All angles are sent as left-justified unsigned 16-bit integers. For example:
14adh --> 31h, 34h, 3ah,3dh.

The position values have calibration factors applied and represent 16-bit binary fractions of a circle. (i.e. 360 degrees divided into 65536 parts) If an axis is not installed, its value is returned as zero.

Function '6' 36 Soft Limits Query

Command [addr]['6']

Response [addr]['6'][x...x]
where x...x is the soft position limit data formatted as follows:

bytes 1-4:	AZ lower soft limit
bytes 5-8:	AZ upper soft limit
bytes 9-12:	EL lower soft limit
bytes 13-16:	EL upper soft limit
bytes 17-20:	F1 lower soft limit
bytes 21-24:	F1 upper soft limit
bytes 25-28:	F2 lower soft limit
bytes 29-32:	F2 upper soft limit

All axes are sent as left-justified unsigned 16-bit integers. For example:
14adh --> 31h, 34h, 3ah,3dh.

The position values have calibration factors applied and represent 16-bit binary fractions of a circle. (i.e. 360 degrees divided into 65536 parts) If an axis is not installed, its value is returned as zero.

Function '7' 37 Move All Axes

Command [addr]['7'][x...x] where x...x is the commanded absolute position formatted as follows.

bytes 1-4:	AZ angle
bytes 5-8:	EL angle
bytes 9-12:	F1 angle
bytes 13-16:	F2 angle

All angles are sent as left-justified unsigned 16-bit integers. For example:
14adh --> 31h, 34h, 3ah,3dh.

The position values have calibration factors applied and represent 16-bit binary fractions of a circle. (i.e. 360 degrees divided into 65536 parts. For the variable-speed controllers, the azimuth and elevation axes are operated at their current fast speed values during the coarse move, and their slow speed values during the fine move.

Response [addr]['7']

Note: The command will be NAK'd under the following conditions:

1. Any of the coordinates are out-of-range.
2. The controller is in local mode.

3. The Remote Lockout flag is set.
4. The controller is in setup mode.
5. The controller is in test mode.
6. The inhibit input is enabled and active.
7. The antenna is already moving.

If an axis is not installed, its value is ignored.

Function '8' 38 Move Axis

Command [addr]['8'][a][x...x] moves the axis a to the commanded absolute position x...x, where a and x...x are formatted as follows:

byte 1: axis select
b6-b2 always 01100
b1-b0: axis select where
 00 = AZ
 01 = EL
 10 = F1
 11 = F2
bytes 2-5: angle data

The axis data is sent as a left-justified unsigned 16-bit integer. For example: 14adh --> 31h, 34h, 3ah,3dh.

The position value has calibration factors applied and represents an unsigned 16-bit binary fraction of a circle (i.e. 360 degrees divided into 65536 parts). For the variable-speed controllers, the azimuth and elevation axes are operated at their current slow speed values.

Response [addr]['8']

Note: The command will be NAK'd under the following conditions:

1. The commanded position is out-of-range.
2. The controller is in local mode.
3. The Remote Lockout flag is set.
4. The controller is in setup mode.
5. The controller is in test mode.
6. The inhibit input is enabled and active.
7. The antenna is already moving.

If the axis is not installed, its value is ignored.

Function '9' 39 Move by Time

Command [addr]['9'][a][t...t] where a is the direction and axis select and t...t is the commanded run time formatted as follows:

byte 1: axis select
b6-b3: always 0110
b2: direction select (1 = up)
b1-b0: axis select where
 00 = AZ
 01 = EL

10 = F1

11 = F2

bytes 2-5: length of time to move the selected axis, in multiples of 4 ms. For the variable-speed controllers, the azimuth and elevation axes are operated at their current slow speed values.

Response [addr] ['9']

Note: The command will be NAK'd under the following conditions:

1. The controller is in local mode.
2. The Remote Lockout flag is set.
3. The controller is in setup mode.
4. The controller is in test mode.
5. The inhibit input is enabled and active.
6. The antenna is already moving.

If the axis is not installed, its value is ignored.

Function ':' 3A Clear Status Change Flag

Command [addr] [':']

Response [addr] [':']

This command clears the status change flag reported in command 31.

Function ';' 3B Set Remote Lockout

Command [addr] [';']

Response [addr] [';']

This command sets (r = 1), or clears (r = 0), the Remote Lockout Flag. When the RL Flag is set, the controller will NAK commands that cause the controller to move the antenna.

Function '<' 3C Aux Out/In

Command [addr] ['<'] [d] where d indicates the following:
 b6-b4: always 011
 b3: auxiliary output 1 mask
 b2: auxiliary output 0 mask
 b1: auxiliary output 1 data
 b0: auxiliary output 0 data

Response [addr] ['<'] [d] [t] where d indicates the following:
 b6-b5: always 01
 b4: enclosure heater on
 b3: auxiliary input 1
 b2: auxiliary input 0
 b1: auxiliary output 1 data

b0: auxiliary output 0 data

and t is the controller internal temperature in Celsius, sent as a left-justified signed 16-bit integer. For example: 14adh --> 31h, 34h, 3ah,3dh.

Note: The auxiliary outputs will only change if they have not been mapped to summary fault or antenna moving function. Refer to the discussion of setup parameters for more information.

Function	'=' 3D	Stop Motion
Command	[addr]['=']	
Response	[addr]['=']	
Comment	This command stops antenna motion. It does not drop out the main contactor in variable-speed controllers (8862/64).	

Function	'>' 3E	Reset Fault
Command	[addr]['>']	
Response	[addr]['>']	
Comment	This command causes the controller to attempt to reset any reported faults. Note that some faults such as limit switch failures will not reset until the fault condition is corrected.	

Function	'?' 3F	Restart controller
Command	[addr]['?']['8861']	
Response	None	
Comment	This command causes the controller to perform a reset, i.e. the unit starts operation from the power-up state.	

Function	'@' 40	Firmware Debug Query
Command	[addr]['@']	
Response	response varies with configuration	
Comment	This command is reserved for firmware development use.	

Function	'A' 41	Change/Read Axis Speed
Command	[addr]['A'][a][r][ss][ff]	

This command sets the current slow speed, represented by ss, and the current fast speed, represented by ff, for axis a, where a is 0 for azimuth and 1 for elevation. Each speed value is formatted as an 8-bit integer representing percentage of base motor frequency (100 % = 50 Hz, for a 50 Hz system). For example: 14h --> 31h, 34h.

Each value can range from the minimum to the maximum values stored in EEPROM. Speed values of zero , or values outside the EEPROM range, are ignored.

If r is 1, the ss and ff values are ignored, and the slow and fast speeds are restored to the default minimum and maximum EEPROM values, respectively.

Response [addr] ['A'] [ss] [ff] The response reports the current slow and fast speeds for the selected axis. Any changes just made are reflected in the response.

Comment This command is ignored for the single-speed controller (8861) and is NAK'd if the antenna is in motion. Note that it is possible to operate at a speed greater than 100 %, subject to motor torque limitations. On power-up or reset, the slow and fast speeds are restored to the EEPROM values.

Function 'B' 42 Enter/Exit Maintenance Mode

Command [addr] ['B'] [d] Where d is a single byte formatted as follows:

b6-b2: 01100
 b1: maintenance mode mask
 b0: maintenance mode flag

With d set to 3, the controller is placed in the maintenance mode in which limit, axis motion, and backward operation faults are ignored. Also, the communication watchdog timer is disabled. With d set to 2, or on power-up, the controller is returned to normal operation. Other values of d are ignored. Changing this mode flag causes the configuration change bit in command #31 to be set.

Response [addr] ['B'] [d] where d is the maintenance mode flag (bit 0 only) as above.

This command will be NAK'd if the antenna is moving, or if the controller is in setup or test modes.

CAUTION: This command disables software safety features, and if used improperly, can result in damage to the antenna or to nearby structures. It is intended to allow the installer to move an axis before the resolvers have been installed or calibrated, and as such, should only be used with extreme care by qualified installation personnel.

Function 'C' 43 Enable/Disable Comm Guard Mode

Command [addr] ['B'] [d] Where d is a single byte formatted as follows:

b6-b2: 01100

b1: comm guard mode mask
 b0: comm guard mode flag

With d set to 3, the controller is placed in the comm guard mode which forces a restart of the controller firmware approximately one minute after the last valid message is received. With d set to 2, or on power-up, the controller is returned to normal operation. Other values of d are ignored. Changing this mode flag causes the configuration change bit in command #31 to be set.

Response [addr] ['B'] [d] where d is the comm guard mode flag (bit 0 only) as above.

This command will be NAK'd if the antenna is moving, or if the controller is in setup or test modes.

Function 'D' 44 Read High Resolution AZ EL

Command [addr] ['D']

Response [addr] ['D'] [x...x]
 where x...x is the high resolution position data formatted as follows:

bytes 1-5: AZ High resolution (20-bit) data
 bytes 6-10: EL High Resolution (20-bit) data

All axes are sent as left-justified unsigned 20-bit integers. For example: 1e4adh --> 31h, 3eh, 34h, 3ah, 3dh.

The position values have calibration factors applied and represent 20-bit binary fractions of a circle. (i.e. 360 degrees divided into 1048576 parts)

Function 'P' 50 Setup Mode

Command [addr] ['P'] [d] With d set to 1, the controller is placed in the setup mode. With d set to 0, the controller is returned to normal operation. This command may be addressed to either device '0' or to the current SAbus address.

Response [addr] ['P']

This command will be NAK'd if the antenna is moving, or if the controller is in test mode. Also, the controller will NAK the command to exit setup mode if any EEPROM writes are currently in progress.

Caution: Address '0' should not be used unless the 8861/2/4 is the only device on the SAbus.

Function 'Q' 51 Read Axis - Uncalibrated

Command [addr] ['Q'] [a] Reads the specified axis, a, where a is 0 for AZ, 1 for EL, 2 for F1, and 3 for F2.

Response [addr] ['Q'] [x..x] Where x..x is the position data formatted as follows:
 bytes 1-4: angle data

The axis data is sent as a left-justified 16-bit integer. For example: 14adh --> 31h, 34h, 3ah,3dh.

The position value has no calibration factors applied and represent a 16-bit binary fraction of a circle (i.e. 360 degrees divided into 65536 parts). If the axis is not installed, its value is returned as zero. The azimuth position is not corrected for southern hemisphere operation.

Comment This command will be NAK'd if the specified axis is not installed.

Function 'R' 52 Move Axis - Uncorrected

Command [addr] ['R'] [a] [x...x] where a is the axis and x...x is the commanded absolute position formatted as follows.

byte 1: axis select
 b6-b3: always 01100
 b1-b0: axis select where
 00 = AZ
 01 = EL
 10 = F1
 11 = F2
 bytes 2-5: angle data

The angle is sent as a left-justified unsigned 16-bit integer. For example: 14adh --> 31h, 34h, 3ah,3dh.

The position value has calibration factors applied and represents an unsigned 16-bit binary fraction of a circle. (i.e. 360 degrees divided into 65536 parts)

This command functions the same as Move Absolute except that it operates on a single axis and the controller does not correct for stopping distance. In preparation for a subsequent Read Stop Time Command, the stopping distance is measured when the axis is stopped. This command is intended for coarse positioning only - it does not peak the antenna into final position. For the variable-speed controllers, the azimuth and elevation axes are operated at their current fast speed values.

Response [addr] ['R']

Note: The command will be NAK'd under the following conditions:

1. The commanded position is out-of-range.
2. The controller is in local mode.
3. The Remote Lockout flag is set.
4. The controller is in test mode.
5. The inhibit input is enabled and active.
6. The antenna is already moving.

If the axis is not installed, its value is ignored.

Function 'S' 53 Move by Time - Uncorrected

Command [addr] ['S'] [a] [t...t] where a is the direction and axis select and t...t is the

commanded run time formatted as follows:

byte 1: axis select
 b6-b3: always 0110
 b2: direction select (1 = up)
 b1-b0: axis select where
 00 = AZ
 01 = EL
 10 = F1
 11 = F2

bytes 2-5: length of time to move the selected axis, in multiples of 4 ms.

Response [addr] ['S']

In preparation for a subsequent Read Stop Time Command, the stopping distance is measured when the axis is stopped. This command is the same as the Move by Time command except that the controller does not measure the stopping distance. For the variable-speed controllers, the azimuth and elevation axes are operated at their current slow speed values.

Note: The command will be NAK'd under the following conditions:

1. The controller is in local mode.
2. The Remote Lockout flag is set.
3. The controller is in test mode.
4. The controller is in setup mode.
5. The inhibit input is enabled and active.
6. The antenna is already moving.

If the axis is not installed, its value is ignored.

Function 'T' 54 Read Stop Distance

Command [addr] ['T'] [a] [u] Where a is the axis command as follows: 0 is AZ, 1 is EL, 2 is F1, 3 is F2. U is 1 for up, 0 for down.

Response [addr] ['T'] [rrdd] Returns the relay drop-out time, rr, and stopping distance, dd, each as two ASCII-encoded digits for the specified axis and direction, a. If the previous move command was not move axis - uncorrected (52) or move by time - uncorrected (53), values of zero are returned.

Note: The command will be NAK'd under the following conditions:

1. The controller is in test mode.
2. The controller is in setup mode.

Function 'U' 55 Set Axis Parameters

Command [addr] ['U'] [a] [pp] [s] [dddd] Sets an axis parameter in non-volatile memory where a is the axis, pp is the parameter no., s is the size ('1'=bit, '8'=byte, '?'=word), and dddd is the parameter, always sent as four ASCII-encoded digits.

Refer to the **DESCRIPTION OF AXIS SETUP PARAMETERS**.

Response [addr]['U'] This command will be NAK'd if the controller is not in setup mode, or if an illegal combination of parameters is received. Also, this command will be NAK'd if the EEPROM write queue is full.

Function 'V' 56 Get Axis Parameters

Command [addr]['V'][a][pp] Gets the axis parameter pp.

Response [addr]['V'][a][pp][s][dddd] Returns the parameter formatted as in command 55 above. If the requested parameter number is reserved, but not yet defined, the length and data are returned as zero.

Function 'W' 57 Set General Parameters

Command [addr]['W'][pp][s][dddd] Sets a general parameter in non-volatile memory where pp is the parameter no., s is the size ('1'=bit, '8'=byte, '?'=word), and dddd is the parameter, always sent as four ASCII-encoded digits. Refer to the **DESCRIPTION OF GENERAL SETUP PARAMETERS**.

Response [addr]['W'] This command will be NAK'd if the controller is not in setup mode, or if an illegal combination of parameters is received. Also, this command will be NAK'd if the EEPROM write queue is full.

Function 'X' 58 Get General Parameters

Command [addr]['X'][pp] Gets the general parameter pp.

Response [addr]['X'][pp][s][dddd] Returns the parameter formatted as in command 57 above. If the requested parameter number is reserved, but not yet defined, the length and data are returned as zero.

Function 'Y' 59 Set Communications Parameters

Command [addr]['Y'][paddr][b] Sets the EEPROM Sabus address and baud rate where paddr is a standard SABus address and b is the baud rate as follows:
 0 - current value is unchanged
 1 - 1200
 2 - 2400
 3 - 4800
 4 - 9600
 5 - 19200
 6 - reserved
 7 - reserved

Response [addr]['Y'] This command may be addressed to either device '0' or to the current SABus address, and will be NAK'd if the controller is not in setup mode, or if an illegal combination of parameters is received. Also, this command will be NAK'd if the EEPROM write queue is full.

Caution: Address '0' should not be used unless the 8861/2/4 is the only device on the SABus.

Note: Changes made by this command will not take affect until the 8861/2/4 is restarted by cycling power, or by command 3F.

Function 'Z' 5A Get Communications Parameters

Command [addr]['Z'] Gets the SABus and baud rate.

Response [addr]['Z'][paddr][b] Returns the EEPROM Sabus address, paddr, and baud rate formatted as in command 59 above. This command may be addressed to either device '0' or to the current SABus address.

Caution: Address '0' should not be used unless the 8861/2/4 is the only device on the SABus.

Function '^' 60 Test Mode

Command [addr]['^']['8861'd]With d set to 1, places the controller in factory test mode. With d set to 0, returns the controller to normal operating mode.

Response [addr]['^'] This command will be NAK'd if the antenna is moving or if the controller is in setup mode.

Function 'a' 61 Test LEDs

Command [addr]['a'][ppp] Lights the front panel LEDs as follows:

byte 0:
b6-b4: always 011
b3: EL Down LED
b2: EL Up LED
b1: AZ Down LED
b0: AZ Up LED

byte 1:
b6-b4: always 011
b3: F2 Down LED
b2: F2 Up LED
b1: F1 Down LED
b0: F1 up LED

byte 2:
b6-b4: always 011
b3: reserved
b2: reserved
b1: FAULT LED
b0: COMM LED

Response [addr]['a'] This command will be NAK'd if the controller is not in test mode.

Function 'b' 62 Read Switches

Command [addr]['b'] Reads the front panel switches.

Response [addr]['b'][ppp]

byte 0:
b6-b4: always 011
b3: F2 Down Switch
b2: F2 Up Switch
b1: F1 Down Switch
b0: F1 Up Switch

byte 1:
b6-b4: always 011
b3: EL Down Switch
b2: EL Up Switch
b1: AZ Down Switch
b0: AZ Up Switch

byte 2:
b6-b5: always 10
b4: E-stop sense (if equipped)
b3: Auxiliary input 2 (if equipped)
b2: auxiliary input 1
b1: auxiliary input 0
b0: Local Switch

Function 'c' 63 Read Limit Switch Inputs

Command [addr]['c'] Reads the limit switch inputs.

Response [addr]['c'][ppp]

byte 0:
b6-b4: always 011
b3: EL Down Limit (NO)
b2: EL Down Limit (NC)
b1: EL Up Limit (NO)
b0: EL Up Limit (NC)

byte 1:
b6-b4: always 011
b3: AZ Down Limit (NO)
b2: AZ Down Limit (NC)
b1: AZ Up Limit (NO)
b0: AZ Up Limit (NC)

byte 2:
b6-b4: always 011
b3: F2 Down Limit (NO)
b2: F2 Down Limit (NC)
b1: F2 Up Limit (NO)

b0: F2 Up Limit (NC)

byte 3:
 b6-b4: always 011
 b3: F1 Down Limit (NO)
 b2: F1 Down Limit (NC)
 b1: F1 Up Limit (NO)
 b0: F1 Up Limit (NC)

Note: This command disables the axis relays and will be NAK'd if the controller is not in test mode.

The appropriate relay driver for the axis and direction must be enabled using command 65 before the limit inputs may be read.

Function 'd' 64 Read Status Inputs

Command [addr]['d'] Reads the axis status inputs.

Response [addr]['d'][ppp]

byte 0:
 b6-b4: always 011
 b3: EL Drive Fault (8862/64 only)*
 b2: AZ Drive Fault (8862/64 only)*
 b1: F2 Status
 b0: F1 Status

byte 1:
 b6-b4: always 011
 b3: EL Down Status
 b2: EL Up Status
 b1: AZ Down Status
 b0: AZ Up Status

byte 2:
 b6-b4: always 011
 b3: F2 Overload trip
 b2: F1 Overload trip
 b1: EL Overload trip
 b0: AZ Overload trip

* Drive Fault bits - in firmware version 2.4 ONLY:
 0 = Fault, 1 = Normal
 These bits will be corrected in V2.5.

Function 'e' 65 Test Relays/Drives

Command [addr]['e'][pppp] Tests the axis relays, where pppp is four bytes formatted as follows:

byte 0:
 b6-b4: always 011
 b3: EL Down Relay

b2: EL Up Relay
 b1: AZ Down Relay
 b0: AZ Up Relay

byte 1:
 b6-b4: always 011
 b3: F2 Down Relay
 b2: F2 Up Relay
 b1: F1 Down Relay
 b0: F1 Up Relay

byte 2:
 b6-b4: always 011
 b3: Master enable
 b2: Heater relay
 b1: Aux Out 2 Relay
 b0: Aux Out 1 Relay

byte 3:
 b6-b4: always 011
 b3: EL decel control
 b2: AZ decel control
 b1: VSD reset
 b0: E-Stop control

Response [addr] [e] rr where rr is two bytes containing the command PAL output state, formatted as in bytes 0 and 1 above.

Note: This command will be NAK'd if the controller is not in test mode.

Note that the up and down outputs for each axis are hardware interlocked; that is, attempting to set the up output while the down output is already set will result in both outputs being cleared.

Function 'f' 66 Read Channel

Command [addr] [f] [dd] Reads the specified channel, dd, where dd ranges from 0 to 23 (17 hex) and is formatted as follows:

byte 0:
 b6-b1: always 011000
 b0: channel MS bit

byte 1:
 b6-b4: always 011
 b3: channel LS+3 bit
 b2: channel LS+2 bit
 b1: channel LS+1 bit
 b0: channel LS bit

Channel numbers are defined as follows:

00	Azimuth resolver	0C	Temperature sensor
01	RDC test angle 1	0D	Azimuth speed signal
02	Elevation resolver	0E	Relay supply voltage
03	RDC test angle 2	0F	Elevation speed signal

04	Feed 1 resolver 10	ADC input - not used
05	RDC test angle 3	11 ADC input - not used
06	Feed 2 resolver 12	ADC input - not used
07	RDC test angle 4	13 ADC half-scale test
08	Feed 1 pot signal	14 ADC zero test
09	Feed 1 pot supply	15 ADC full scale test
0A	Feed 2 pot signal	16 not used
0B	Feed 2 pot supply	17 not used

Response [addr][f][x..x] Where x..x is the channel data formatted as follows:

bytes 1-4: angle data

The axis data is sent as a left-justified 16-bit integer. For example: 14adh --> 31h, 34h, 3ah,3dh.

The position value has no calibration factors applied and represent a 16-bit binary fraction of a circle (i.e. 360 degrees divided into 65536 parts). If the axis is not installed, its value is returned as zero.

Note: This command changes the internal channel scheduler and will be NAK'd if the controller is not in test mode.

Function 'g' 67 Test R/D Converter

Command [addr][g] Selects resolver mux channel T1R, and writes its previous value minus 90 counts to the R/D converter.

Response [addr][g][f] Waits one clock tick, reads the selected channel, and compares the reading to the previous value. If the difference between the two readings is within two RDC counts, f is returned as FALSE, 30h, otherwise it is returned as TRUE, 3fh.

Note: This command changes the internal channel scheduler and will be NAK'd if the controller is not in test mode.

Function 'h' 68 Test Reference Frequency

Command [addr][h] Measures the period of the 7500 Hz resolver reference.

Response [addr][h][dddd] Returns the period of the signal in internal timer units.

Function 'i' 69 Test PWM Outputs

Command [addr][i][aa][ee] Sets the azimuth and elevation speed reference outputs to aa and ee respectively, where aa and ee are formatted as 8-bit integers representing the percentage of base motor frequency (100 % = 50 Hz, for a 50 Hz system). For example: 14h --> 31h, 34h.

Response [addr][i]

Function 'j' 6A Reserved

reserved for internal use.

Function	'k' 6B	Initialize EEPROM
Command	[addr]['k']['8861'] Initializes the contents of the internal EEPROM to a default (factory) state then resets the controller. Further communication is inhibited until the initialization and reset is complete.	
Response	none (unless NAK'd)	
	This command will be NAK'd if the controller is not in test mode.	

Caution: This command causes all setup parameters to be lost.

Function	'j' 6C	Reserved
Function	'k' 6D	Reserved
Function	'l' 6E	Reserved

reserved for internal use.

Function	'o' 6F	Test COP Timer
Command	[addr]['o']['8861']	
Response	None	
Comment	If the COP timer has been enabled and is operating properly, this command forces a timeout followed by a restart. This command is the same as command 3F, Restart Controller.	

Function	'p' 70	Reserved for 8860 Passthru Mode
-----------------	---------------	--

reserved for exclusive use by 8860.

Function	'~' 7E	Comm Status Query
Command	[addr]['~'][d]	
Response	[addr]['~'][n...n] Where n...n is the number of errors, reported as a left-justified unsigned 16-bit integer.	
	This query returns the number of communication errors since the counter was last reset. With d set to 1, the counter is reset.	

DESCRIPTION OF AXIS SETUP PARAMETERS

In the descriptions that follow, the default values are shown in the form [1, 2, 3, 4] where the values refer to the azimuth, elevation, feed 1, and feed 2 axes respectively. Unless noted otherwise, all binary parameters are positive logic (0 = FALSE, 1 = TRUE).

<u>parameter</u>	<u>description</u>	<u>size</u>	<u>default</u>
00h	axis installed This parameter indicates that the axis hardware is present on the antenna. For example a system with only one motorized feed will have the feed 2 installed parameter set to 0.	bit	[1,1,0,0]
01h	axis calibrated This parameter is not currently used by the controller.	bit	[0,0,0,0]
02h	axis data pot This parameter indicates that the axis position transducer is a potentiometer instead of a resolver. This parameter is only valid for feed 1 and feed 2.	bit	[0,0,1,1]
03h	alternate dir This parameter is used to correct for a transducer indicating backwards rotation. Note that setting this parameter does not correct for backward motor rotation or swapped limit switches as these items are hardwired.	bit	[0,0,0,0]
04h	axis trip mask This parameter is set to mask the overload trip input for an axis whose overload device is not equipped with an auxiliary contact. Note that setting this bit does not prevent the device from tripping.	bit	[0,0,0,0]
05h	axis fault mask This parameter is not currently implemented.	bit	[0,0,0,0]
06h	soft limit pos up	word	0xffff [all]
07h	soft limit pos down These limits may be set to restrict motion of the antenna to a specified range. They should not be used to prevent the antenna from hitting an obstruction - the mechanical limits must be adjusted for this purpose.	word	0 [all]
08h	hard limit pos up	word	0xffff [all]
09h	hard limit pos down These parameters indicate the positions to which the physical limit switches are adjusted.	word	[0,0,0,0]
0ah	axis offset	word	[0,0,0,0]
0bh	axis scale numerator	word	0x4000 [all]
0ch	axis scale denominator These parameters are used to scale the position transducer reading to the correct value. The scaling is in the form:	word	0x4000 [all]

$$Y = X * (\text{numerator/denominator}) + \text{offset}$$

The numerator and denominator are not used for azimuth and elevation as these transducers are always directly coupled to the mount pivots with no gearing, ie. 90E mechanical rotation results in 90E electrical travel.

0dh	axis position report differential	byte 0x02 [all]	This parameter controls position change reporting - a change in position larger than this parameter causes the status change flag to be set.
0eh	axis minimum slew distance	word 0x0008 [all]	This parameter determines the minimum coarse move that may be made. If the difference between commanded and present position is less than this parameter, the coarse move is skipped, otherwise the coarse move takes place. The correct value for this parameter is dependent on antenna speed.
0fh	axis minimum peak distance	word 0x0004 [all]	This parameter determines the minimum fine move that may be made. If the difference between commanded and present position is less than this parameter, the axis is backed out during the coarse move. The correct value for this parameter is dependent on antenna speed.
10h	axis minimum move distance	word 0x0002 [all]	This parameter determines the minimum move distance. If the difference between commanded and present position is less than this parameter, the move for this axis is not performed.
11h	axis checkpoint position	word 4 [all]	Periodically, during antenna motion, each axis position is checked to see if it is actually changing. The time parameter determines how often the position is checked, in 250 ms increments. The position parameter determines the minimum change, in position (in converter counts) required for normal operation. If the change in position is less than this parameter, it is reported as a motion fault and indicates a possible stuck actuator or motor failure. The direction of motion is also checked and, if reversed, is reported as a backward operation fault. The correct values for these parameters are dependent on antenna speed.
12h	axis checkpoint time	byte 4 [all] (>V1.2)	
13h	axis minimum speed	byte [10]	These parameters specify the minimum and maximum speed for the axis and represent the percentage of base motor frequency (e.g. 200 % = 100 Hz, for a 50 Hz system). They are only applicable for the variable-speed controllers (8862/64).
14h	axis maximum speed	byte [200]	
15h	checkpoint enable	bit [1,1,1,1]	This parameter, if set to 1, enables the checkpoint feature as described above.
16	retry pulse width	byte 0 [all]	This parameter determines the on time, in 4 ms clock ticks for a position retry pulse. This number represents the time that the contactors are driven on and does not include the contactor release time.

17 **retry maximum count** **byte 0 [all]**
This parameter determines the maximum number of position retrys that will be made. Setting this paramter to zero prevents any position retrys from being made.

18h-1fhreserved

20h-27h **axis stop distance up** **byte**
28h-2fh **axis stop distance down** **byte**
These parameters are used to correct for overtravel when stopping the antenna at the desired position.

30h-37h **axis speed up** **byte**
38h-3fh **axis speed down** **byte**
These parameters are not currently implemented.

PARAMETERS DESCRIPTION OF GENERAL SETUP

<u>parameter</u>	<u>description</u>	<u>size</u>	<u>default</u>
00h	EEPROM configuration number This parameter reports the version number of the internal EEPROM data structure and is read only. It is intended to be used to prevent incompatibility between different version of firmware and test/calibration software.	word	0x0002
01h	special power mode Setting this parameter to 1 forces sequential operation of the axes during the coarse move cycle. This mode of operation is used for special applications where the available input power is limited.	bit	0
02h	variable speed mode Setting this parameter to 1 indicates that variable-speed control is available for the azimuth and elevation axes.	bit	0 (8862/64 only)
03h	temp fault mask Setting this parameter to 1 causes the controller to mask enclosure low and high temperature alarms.	bit	0
04h	summary fault output enable Setting this parameter to 1 designates auxiliary output 0 as a summary fault output function. Otherwise this output may be turned on or off via command 3C.	bit	0
05h	antenna moving output enable Setting this parameter to 1 designates auxiliary output 1 as an antenna motion output function. Otherwise this output may be turned on or off via command 3C.	bit	0
06h	external fault input enable Setting this parameter to 1 designates auxiliary input 0 as an external fault input.	bit	0
07h	inhibit motion input enable Setting this parameter to 1 designates auxiliary input 1 as a motion inhibit input.	bit	0
08h	communication watchdog enable Setting this parameter to 1 causes remote-commanded antenna motion to be stopped in the event that communication with the host device is lost (Approx. 1 sec. timeout).	bit	1
09h	temperature control enable Setting this parameter to 1 enables enclosure temperature control.	bit	1
0ah	temp scale numerator	word	0x01f0
0bh	temp scale denominator	word	0xfde8
0ch	temperature offset	word	0xfef5
	These parameters are used to scale the enclosure temperature sensor		

reading to the correct value in degrees Celsius. The scaling is in the form:

$$Y = X * (\text{numerator/denominator}) + \text{offset}$$

0dh	temperature setpoint	word 0	This parameter determines the temperature at which the heater (8861/62) or fan (8864) is turned on.
0eh	temperature lower limit	word 0xffd8	These parameters determine the limits for enclosure temperature fault reporting.
0fh	temperature upper limit	word 0x0041	
10h	southern hemisphere flag	bit 0 (V1.2)	Setting this parameter to 1 allows the controller to properly handle the azimuth position discontinuity (359.99 -> 0.00 deg.) in the southern hemisphere.
11h	high resolution AZ, EL	bit 0 (8864 only)	Setting this parameter to 1 indicates that the installation is equipped with 1X-4X coarse/fine resolvers for improved position accuracy (8864). In this configuration, the F1 and F2 resolver inputs are used for the AZ and EL fine inputs respectively.
12h	fan cooling mode	bit 0 (8864 only)	Setting this parameter to 1 causes the temperature control logic to be reversed, turning on the heater/fan relay when the temperature exceeds the setpoint.
13h	e-stop mask (for V1.0 H/W)	bit 1 (8861 only)	This parameter is set to 1 to indicate that the controller is not equipped with an emergency stop relay.

Function **'K' 4B Get Axis Statistics**

Command [addr]['K'][a] Where a is the axis('0'-'3').

Response [addr]['K'][m][s][g] Where m is the number of commanded moves since power-on, s is the number of axis starts since power-on, and g is the number of position glitches (bad readings) since power-on. Note that a Move All Axes command (#37) may result in two commanded moves for each affected axis.

The m, s, and g fields are sent as left-justified unsigned 16-bit integers, each encoded as four ascii-hex digits. For example: 14adh --> 31h, 34h, 3ah,3dh.

Function **'L' 4C Setup Position Analyzer**

Command [addr]['L'][m][a][f][ss] Where m is the change mask ('0' or '1'), and a is the axis to be monitored ('0'-'3'). The ss field is the number of samples to skip during monitoring, encoded as 2 ascii-hex digits. The f field is a single byte formatted as follows:

b6-b3: 0110

b2: circular buffer mode flag

b1: automatic start/stop mode flag

b0: position analyzer enable flag

Response [addr]['L'][a][f][ss] Where a, f, and ss are formatted as above.

Function **'M' 4D Get Position Analyzer Status**

Command [addr]['M']

Response [addr]['M'][f][i][c][s] Where f is the active flag ('0' or '1'), i is the current buffer index, c is the number of samples collected, and s is the buffer position where axis motion stopped.

The i, c, and s fields are sent as left-justified unsigned 16-bit integers, each encoded as four ascii-hex digits. For example: 14adh --> 31h, 34h, 3ah,3dh.

Function **'N' 4E Get Next Position Data Record**

Command [addr]['N'][s] Where s is the buffer selector:

'0' = averaged position data (default)

'1' = raw position data

'2' = time stamp data

Response [addr]['N'][i][d..d] Where i is the buffer index for the first data value and d..d is the next eight data values.

The index and data values are sent as left-justified unsigned 16-bit integers, encoded as four ascii-hex digits. For example: 14adh --> 31h, 34h, 3ah,3dh.

Function	'O' 4F	Set/Get Position Data Index
Command		[addr] ['O'] [f] [i] Where f is the new index flag and i is the new buffer index. With f set to 1, if i is in range the buffer index is changed to i, otherwise, the buffer index is set to zero.
Response		[addr] ['O'] [i] Where i is the buffer index. The index is sent as a left-justified unsigned 16-bit integer, encoded as four ascii-hex digits. For example: 14adh --> 31h, 34h, 3ah, 3dh.